

VIRGINIA TECH

magazine

SPRING 2019

CAPITAL COLLABORATION

The partnership that drew Amazon to Northern Virginia

RESEARCH IN ROANOKE

World-class scientists advance discoveries in health sciences and technology

RECORD-BREAKING GIFT

\$50M gift fuels biomedical research

DESTINATION DUBAI

FutureHAUS wins global competition

FINDING A NICHE

Alumnus scores internet retail win with pickleball

INSIDETECH

WHAT DOES THE MODERN LAND-GRANT LOOK LIKE?



PRESENTS

REUNION WEEKEND 2019



REGISTER NOW FOR YOUR
SUMMER REUNION WEEKEND – JUNE 6-9, 2019

> ALUMNI.VT.EDU/REUNION2019 <

GET THE LOOK

hokiegear.com



CONTENTS

ON EXHIBIT

The process of selecting, securing, and installing the gallery exhibits in the Moss Arts Center involves careful research and painstaking planning. Each piece of art is hand-selected and must be thoroughly examined on arrival by experts like Ashley Webb, registrar and museum collections specialist. Turn to page 16 to learn more.



FEATURES

24 INSIDE TECH: WHAT DOES THE MODERN LAND-GRANT LOOK LIKE?

- 24 Virginia Tech's plans to accelerate workforce development and technology through the Innovation Campus in Northern Virginia helped lure Amazon to the commonwealth.
- 28 The Fralin Biomedical Research Institute at VTC is advancing medical discoveries and improving the economic landscape in Roanoke.
- 32 The culmination of nearly two decades of research and development that included contributions from more than 100 students and faculty, FutureHAUS Dubai won top honors at the 2018 Solar Decathlon Middle East.

36 HOKIE AT HEART

A \$50 million gift for biomedical research is the largest in Virginia Tech's history.

DEPARTMENTS

4 PRESIDENT'S MESSAGE

6 AROUND THE DRILLFIELD

- 16 How Tech Ticks
- 18 Athletics
- 20 Corps
- 21 What's In It?
- 22 Ology

42 AROUND THE HOKIE NATION

- 42 Alumnus Profile: Justin Graves
- 45 Class Notes
- 54 Travel Profile
- 58 Retro
- 63 Alumni Commentary
- 64 Family

70 STILL LIFE

72 END NOTE



ON THE COVER: The exterior panels on FutureHAUS Dubai. Photo by Erica Corder '16, communications manager for the College of Engineering. (at right) K-9 COP: Zuka is a new officer of the Virginia Tech police force. His handler is Officer Jaret Reece.



PRESIDENT'S MESSAGE

BREAKING NEWS: Virginia Tech President Tim Sands fields questions from the media during an event on Dec. 6, 2018, announcing a record \$50 million gift from the Horace G. Fralin Charitable Trust and Heywood and Cynthia Fralin to the Fralin Biomedical Research Institute at VTC.

BIG IDEAS, BOLD MOVES

It's always a great year to be a Hokie, but 2019 is shaping up to be one of our best yet.

Last year we began implementing our Beyond Boundaries vision to advance Virginia Tech's modern land-grant mission with some big ideas and ambitious goals. Working together, with your support, our planning and strategy are already making a difference and producing some remarkable opportunities.

In November, Virginia Tech was center stage as Amazon announced plans to expand to Arlington, Virginia. Our commitments to build an Innovation Campus in nearby Alexandria and to increase the undergraduate pipeline to produce top-notch talent were among the key components that led to the decision. Just a few weeks later in Roanoke, we were honored to celebrate the naming of the Fralin Biomedical Research Institute at VTC, in recognition of the generosity of the Horace G. Fralin Charitable Trust and Heywood and Cynthia Fralin. Their gift will support significant expansion of our growing Academic Health Center. Big things are also happening in Blacksburg, where the Board of Visitors approved a new master plan that supports smart growth and development of our main campus.

Today, we face the same imperative that energized our predecessors to grow and evolve. Virginia Tech is in a strong position, with momentum, energy, and opportunity on our side. We have a strong leadership team in place, having recently selected Cyril Clarke as executive vice president and provost and Lee Learman as dean of the Virginia Tech Carilion School of Medicine.

Your support is also invaluable to our continued success, and there are so many ways you can be involved. You can make an impact by:

- Joining an alumni chapter in your region.
- Attending our Reunion Weekend in June.
- Creating a student internship at your place of business.
- Volunteering to share your expertise in the classroom.
- Donating during Virginia Tech's Giving Day on March 19.

With the support of the Hokie Nation and a commitment to service in the spirit of *Ut Prosim* (That I May Serve), we will continue to seek excellence with a strategic focus on our priorities.

Working together in true Virginia Tech fashion, we will succeed.

We have an exciting future ahead. ■

Tim Sands is Virginia Tech's 16th president.

VIRGINIA TECH MAGAZINE
SPRING 2019, VOL. 41, NO. 2

EDITOR
Erica Stacy

ASSISTANT EDITOR
Mason Adams

ART DIRECTOR
Shanin Glenn

WRITERS
Jenny Kincaid Boone, Richard Lovegrove,
Travis Williams, Grace Baggett (student
intern), Brendan Coffey (student intern)

DESIGNERS
Bruce Harper (webmaster)

PRODUCTION COORDINATOR
Megan Zalecki

PHOTOGRAPHERS
Olivia Coleman, Dan Mirolli, Ray Meese,
Erin Williams

DIRECTOR OF DESIGN & DIGITAL STRATEGY
Brad Soucy

EXECUTIVE EDITOR
Jesse Tuel

**SENIOR ASSOCIATE VICE PRESIDENT
FOR ALUMNI RELATIONS**
Matthew M. Winston Jr.

PUBLISHER
Tracy Vosburgh

CONTACTS

STORY IDEAS AND LETTERS TO THE EDITOR:
EMAIL: VT.MAG@VT.EDU. **MAIL:** VIRGINIA TECH MAGAZINE;
902 PRICES FORK ROAD; UNIVERSITY GATEWAY CENTER,
SUITE 2100; BLACKSBURG, VA 24061. **ADDRESS CHANGES:**
EMAIL: ALUMNIDATA@VT.EDU. **PHONE:** 540-231-6285
BETWEEN 8 A.M. AND 5 P.M., MONDAY THROUGH FRIDAY.
CLASS NOTES: EMAIL: CLASSNOTES@VT.EDU. **MAIL:**
CLASS NOTES, ALUMNI ASSOCIATION; HOLTZMAN
ALUMNI CENTER, VIRGINIA TECH; 901 PRICES FORK RD.;
BLACKSBURG, VA 24061. **ADVERTISING:** IMG COLLEGE,
BRANDON.FORBIS@IMG.COM, 540-641-0754.

Virginia Tech does not discriminate against employees, students, or applicants on the basis of age, color, disability, gender, gender identity, gender expression, national origin, political affiliation, race, religion, sexual orientation, genetic information, or veteran status; or otherwise discriminate against employees or applicants who inquire about, discuss, or disclose their compensation or the compensation of other employees, or applicants; or any other basis protected by law. For inquiries regarding nondiscrimination policies, contact the executive director for Equity and Access at 540-231-8771 or Virginia Tech, North End Center, Suite 2300, 300 Turner St. NW, Blacksburg, VA 24061.



SOMETHING TO SAY?
Send us a message at vtmag@vt.edu.

LETTERS

TO THE EDITOR

STRAIGHT-UP

It was interesting to read your story on Hokie alumni in the craft brewing industry (fall 2018, page 34).

My husband, Russell Nance '94, and I are part owners in Ragged Branch Distillery in Charlottesville, Virginia, and we thought your readers might be interested in hearing about the Virginia Tech connections within our business as well as the agricultural component.

Ragged Branch Distillery produces two types of Virginia Straight Bourbon Whiskey, a rye-based bourbon and a wheat-based bourbon, as well as bourbon mash fed beef. Ragged Branch grows its own corn, wheat, and rye, which are ground and cooked daily. At the end of the distillation process, we feed the spent mash to our cattle (the alcohol has evaporated out). We sell the bourbon and beef in an on-site

tasting room, and our bourbon is available in Virginia ABC stores as well as stores in Washington, D.C.; Maryland; Delaware; and Louisiana.

Our production team consists of recent Virginia Tech agriculture grads Josh Toomy '14 and Chris Coggin '13. They tend to the farm and the cattle, run the still, and so much more.

We have been in discussions with the Virginia Tech Agriculture Summer Internship Program regarding employing an intern.

We think our business is another great story about how Virginia Tech grads put their degrees to work in interesting ways.

*Chrissy Nance
New York, New York*



CORRECTION

On page 45 of the fall 2018 issue of Virginia Tech Magazine, the class notes for Richard M. Arnold and Charles E. Hamner Jr. were listed incorrectly under the Class of '49. These alumni are members of the Class of '56.

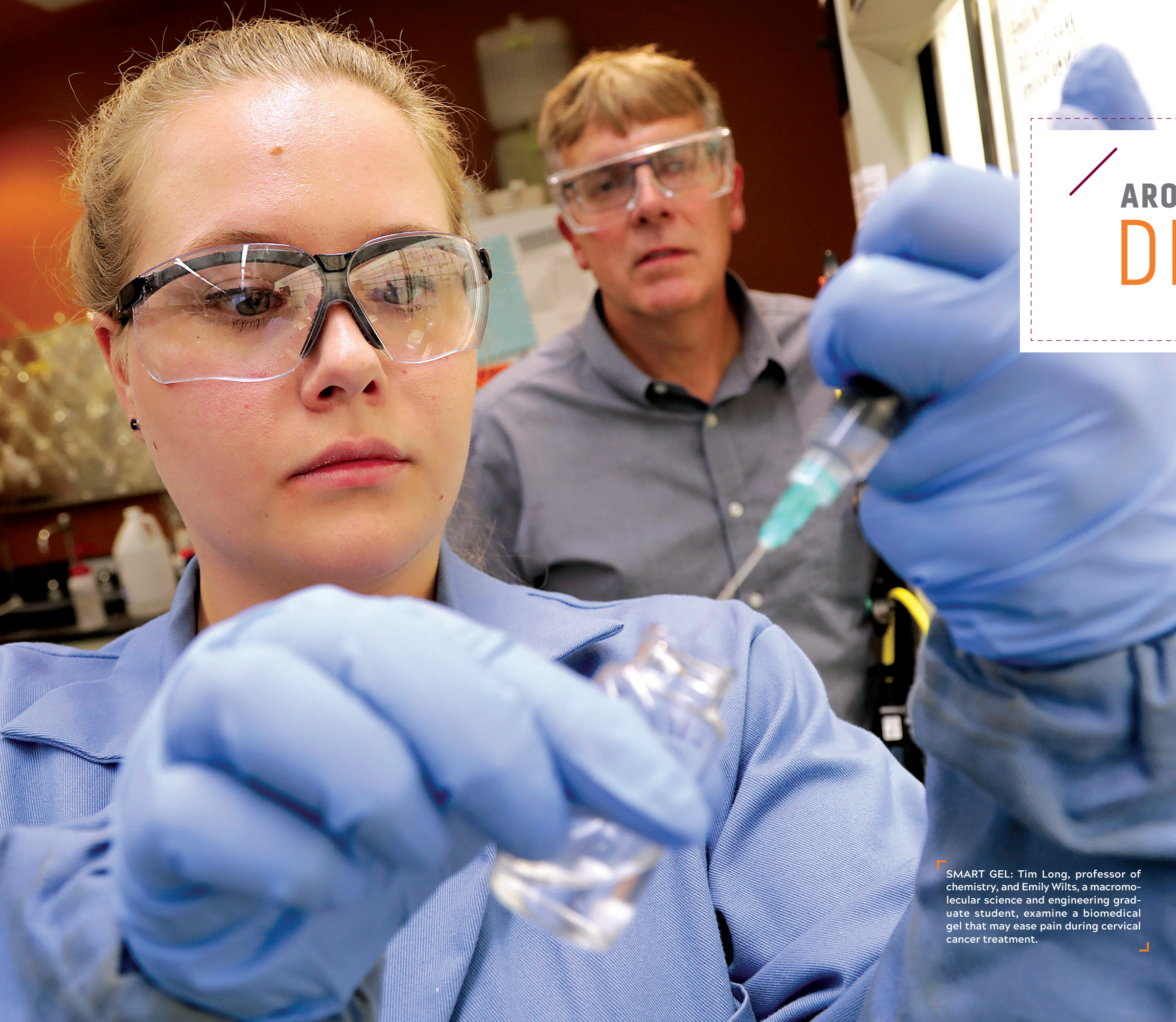

AROUND THE DRILLFIELD

- 16 How Tech Ticks
- 18 Athletics
- 20 Corps
- 21 What's In It?
- 22 Ology

NEWS

NEW BIOMEDICAL GEL COULD EASE PAIN IN CERVICAL CANCER TREATMENT

A UNIQUE PARTNERSHIP BETWEEN A VIRGINIA TECH scientist and a University of Virginia (UVA) oncologist could result in a solution to reduce discomfort during cancer treatment for women.

Tim Long, a professor of chemistry with the Virginia Tech College of Science, and Tim Showalter, a radiation oncologist at UVA's Cancer Center, are testing a gel that could be used during radiation treatment for cervical cancer.

At his Charlottesville clinic, Showalter performs brachytherapy. It involves inserting radioactive material directly into cancerous tissue. For patients who have cervical cancer, the radiation is inserted directly into the cervix.

But this outpatient procedure, which Showalter performs at least five times for each patient, often is so painful and uncomfortable that some women need anesthesia.

"If we can do something to reduce the amount of discomfort during the procedure, it's a really big deal," Showalter said.

His hunt for a solution began four years ago. He initially sought out chemical engineers at UVA, but he kept hearing about Long, who is well-known for his work in polymer chemistry at Virginia Tech. Long directs the university's Macromolecules Innovation Institute and oversees a diverse group that has received

SMART GEL: Tim Long, professor of chemistry, and Emily Wilts, a macromolecular science and engineering graduate student, examine a biomedical gel that may ease pain during cervical cancer treatment.

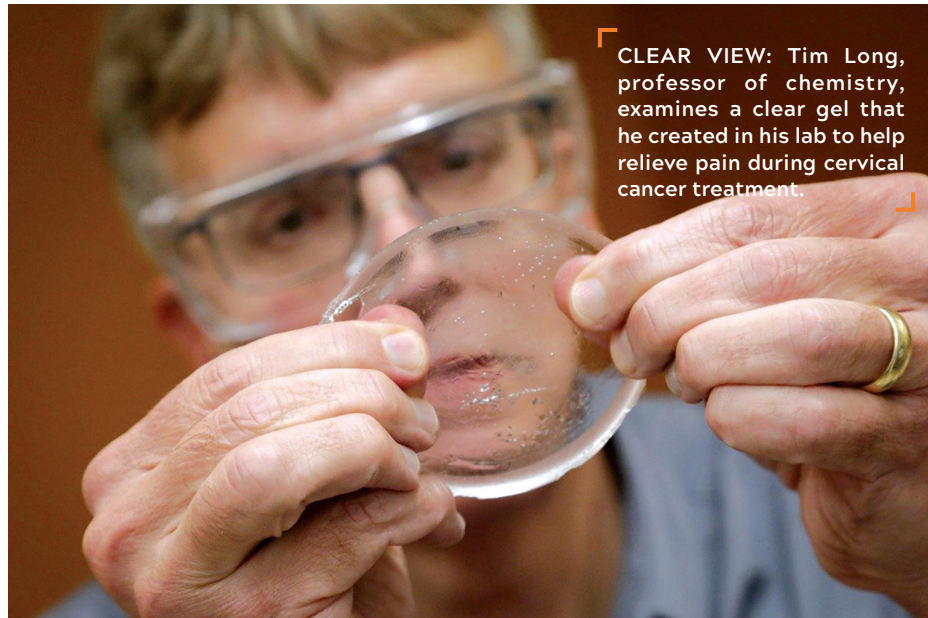

CLEAR VIEW: Tim Long, professor of chemistry, examines a clear gel that he created in his lab to help relieve pain during cervical cancer treatment.

more than \$50 million in research funding during the past 18 years. He has more than 50 patents in macromolecular science and engineering, and in 2015, he was one of three people named Virginia Scientist of the Year.

Long was the perfect choice for the job, Showalter said.

He approached Long with his idea, and the two became a team. They discussed the work during video conferences and visited each other's labs and clinics.

Long had never before designed a product for use in a human body, but, he said, it is one of his ultimate goals. Similarly, Showalter has never created a medical product.

"We complemented each other," said Long.

Long and Showalter initially received funding for the project through a 4-VA grant. Long and Showalter also have received funding from other sources in the past few years, including the National Institutes of Health.

Initially, Showalter suggested creating a

spray foam substance, but it was Long's idea to go with a hydrogel.

In his Virginia Tech lab, Long, along with a postdoctoral scholar, Nicholas Moon, used click chemistry, which is a fast reaction, to create what he coined a "smart" gel that moves and forms fast in parts of the body.

"The reaction happens in the body," Long said. "Within two minutes, the gel fills the space."

The gel isolates the tumor and becomes soft by adding water.

The idea is for a physician to insert this gel into a patient before radiation treatment, said Showalter.

Showalter created a Charlottesville-based company, Brachyfoam, to develop the gel product, with both UVA and Virginia Tech working to develop the patent.

So far, Showalter has tested the gel's performance in human cadavers, and it performed well, he said. ■

VIRGINIA COOPERATIVE EXTENSION AWARDED NEARLY \$1.1 MILLION TO TACKLE OPIOID EPIDEMIC



THE U.S. DEPARTMENT OF HEALTH and Human Services has awarded Virginia Cooperative Extension nearly \$1.1 million to expand prevention training to help tackle the commonwealth's rural opioid addiction problem.

The two-year Substance Abuse and Mental Health Services Administration-funded Rural Opioids Technical Assistance Through Virginia Cooperative Extension project will build upon two current U.S. Department of Agriculture-funded Cooperative Extension projects to expand training and technical assistance on opioid prevention through the implementation of evidenced-based curricula targeting students in nine additional rural Virginia counties.

Rural communities are disproportionately affected by prescription opioid misuse and abuse. Of 134 counties or independent cities in Virginia, 53 are designated as rural. ■

FIVE-YEAR ENERGY ACTION PLAN ON TRACK TO YIELD \$6 MILLION IN ENERGY COST SAVINGS

WHEN THE VIRGINIA TECH OFFICE of Energy Management conducted an energy benchmarking analysis of buildings on the main Blacksburg campus in 2015-16, it discovered just 50 buildings accounted for more than 70 percent of overall university energy costs.

That discovery prompted the Five-Year Energy Action Plan, a comprehensive blueprint to improve energy efficiency and reduce energy costs within five years in the 50 most energy-intensive buildings.

Since 2016, three phases of the plan have been implemented, with 10 new energy-intensive buildings incorporated into each phase.

As a result, the university has already reduced its carbon emissions by about 15,000 tons per year and saved more than \$2 million in energy costs; full integration of the plan is expected to yield more than \$6 million in overall energy cost savings.

More than \$3.5 million in funding approved in October 2018 will help propel the plan into its fourth phase and deepen the university's energy conservation efforts. ■



ENERGIZED: Virginia Tech Facilities Department advances energy savings.

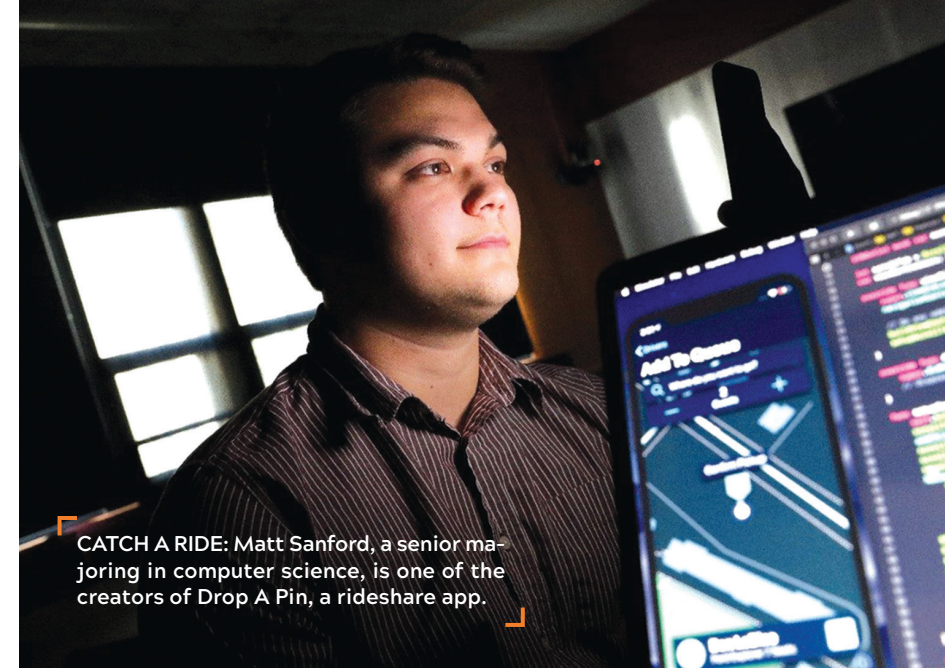

CATCH A RIDE: Matt Sanford, a senior majoring in computer science, is one of the creators of Drop A Pin, a rideshare app.

STUDENTS CREATE DESIGNATED-DRIVER RIDESHARE APP

AFTER COUNTLESS STRESSFUL SHIFTS serving as designated drivers for Phi Sigma Kappa fraternity events in Blacksburg, Matt Sanford and Greg Smith have devised a safer way to give rides to students who have been drinking.

Sanford, a senior majoring in computer science, and Smith, an accounting and finance double major who graduated from Virginia Tech in 2015, created Drop A Pin (DAP), a rideshare mobile platform that connects students with designated drivers.

"The main goal is to get drivers to focus on driving, not talking on the phone," said Sanford.

This is how it works: An organization can purchase a monthly or yearly subscription to use the app for certain events. Once subscribed, users receive a code that connects them with a network of designated drivers available on a specific date and time. The app provides data to the user about the size of the vehicle, the driver, and the pick-up location. Drivers can focus on driving without having to use their phones to talk or text with people needing rides.

Rides are free for Virginia Tech students who belong to organizations that use

DAP. Each organization supplies the drivers and runs its own designated driving program through the app. Other schools also can sign up to use the app.

Sanford and Smith plan on making DAP a for-profit business in the future.

Saharsh Shrivastava and Abhinav Oddula, both senior computer science majors at Virginia Tech, helped with the Android version. Tevin Scott, who received his bachelor's in computer science from Radford University, and Sanford created the iPhone version.

"DAP not only helps students get home safely, it strives to decrease drinking and driving on college campuses. This is a goal for Hokie Wellness, too," said Kelsey O'Hara, health educator for Hokie Wellness.

"With designated driving in particular, a lot of times our education is centered around bystander intervention," O'Hara said. "We promote people to never drive after drinking; a lot of times we will say 'impairment starts with the first sip.' That's our philosophy, because once you start drinking, you are impaired. So, never drive while drinking, don't ride with someone who has been drinking, and step up if you see a situation occurring." ■



SEEING RED: NASA'S new InSight Lander arrived on Mars in November.

GEOSCIENCES RESEARCHERS WILL USE DATA FROM NEW NASA LANDER TO LEARN ABOUT MARS

WHEN NASA'S NEW INSIGHT LANDER touched down on Mars on Nov. 26, 2018, to begin new explorations of the Red Planet's interior structure, Virginia Tech's Scott King anxiously awaited the first feedback of data.

King, a professor with the Department of Geosciences in the Virginia Tech College of Science, heads one of 24 research teams selected this past summer by NASA to receive data science collected by the lander as it explores the planet during the next four years. When InSight—that's short for Interior Exploration using Seismic Investigations, Geodesy, and Heat Transport—arrived on Mars after its 301-million-mile journey, the robotic explorer took on the mission of studying Mars' crust, mantle, and core.

In NASA's words, this first-of-its-kind mission will "give the Red Planet its first thorough checkup since it formed 4.5 billion years ago." In King's words, "I'll be thinking a lot about what's inside Mars for the next few years." King will focus on the size of Mars' core and how it moves and wobbles, or rotates.

"At the end of the project, I hope that we

have a model for the composition of the interior of Mars, including the composition of the core, the size of the core, and the composition of the rocky mantle above it," King said. "I hope this model will be consistent with all the available observations we have—from InSight, from Martian meteorites, from the compositions of the surface rocks from the rovers, and from the global models of gravity and topography. Knowing the composition will help us understand Mars' evolution through time: When did the magnetic field start and stop? And why did it stop? What is the origin of the large volcanoes and why are they on one hemisphere of Mars?"

InSight's exploration of Mars is not King's first project with NASA. He was part of the Dawn at Ceres mission and is continuing to study Ceres, the largest body in the asteroid belt. He has published papers on Mercury, Venus, Earth, and Mars. The Red Planet, though, has remained a top focus.

Josh Murphy, a geosciences doctoral student from Stafford, Virginia, will work with King on the project. ■

ON TWO WHEELS

STEVE HANKEY HAS DEVELOPED a unique way to track air pollution.

However, the experiments of this assistant professor of urban affairs and planning at Virginia Tech do not take place in a lab. They happen in the streets of Blacksburg. On a bicycle.



The bicycle, a Specialized Turbo X, monitors air pollution to track hot spots over time.

"The idea is to combine all of this information to look for where you can design healthy neighborhoods that promote physical activity and protect against air pollution exposure," said Hankey, who, along with several undergraduate and graduate students, has finished his research and submitted it for publication.

He hopes to receive funding to expand the research to Washington, D.C., this summer.

Hankey's research from previous air monitoring work has appeared in multiple publications, including Environmental Science & Technology, Atmospheric Environment, and Environmental Health Perspectives. ■

IMAGE COURTESY OF NASA, RM

COURTESY OF DR. LEE LEARMAN, MICHELLE TUREK

NEW DEAN NAMED

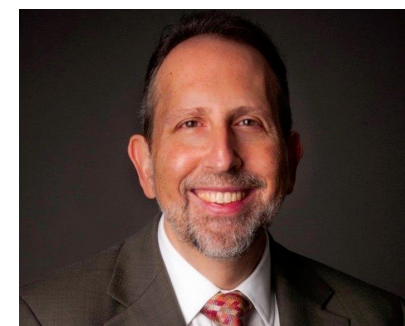

LEE A. LEARMAN, A PHYSICIAN, researcher, and educator, has been named the next dean of the Virginia Tech Carilion School of Medicine following a nationwide search. Learman will begin in the role July 1.

"I'm honored by the opportunity to serve as dean of the Virginia Tech Carilion School of Medicine. In its first decade of existence, it has built a solid foundation drawing on the strengths of both an outstanding public research university and an outstanding private health system," said Learman.

Learman has 25 years of progressive leadership experience in medical education and health care. He currently serves as the senior associate dean for academic affairs and the senior associate dean for graduate medical education at the Florida Atlantic University's Charles E. Schmidt College of Medicine.

From 2008 to 2015, Learman served at Indiana University. Prior to 2008, he spent 14 years on the faculty at the University of California San Francisco.

Learman received his bachelor's degree from the University of California Los Angeles, his M.D. from Harvard Medical School, and a Ph.D. in social psychology from Harvard University. ■



EQUINE MEDICAL CENTER DEDICATES RENOVATED YOUNGKIN EQUINE SOUNDNESS CLINIC

EQUINE ATHLETES OF ALL KINDS IN THE Mid-Atlantic region will now have access to an enhanced sports medicine facility.

The Youngkin Equine Soundness Clinic in the Fout Barn at Virginia Tech's Marion duPont Scott Equine Medical Center at Morven Park was dedicated at a ribbon-cutting ceremony held on Nov. 18, 2018, at the center in Leesburg, Virginia.

The renovation of the former open-air barn into a state-of-the-art sports medicine facility, made possible by a generous gift from Suzanne and Glenn Youngkin of Great Falls, Virginia, expands the center's capacity to provide cutting-edge diagnostics and treatment for lameness and other conditions.

The clinic is comprised of four holding stalls; two comfortable client waiting and observation areas; and a large open examination, diagnostic, and treatment area. There, specialists will employ an integrated approach to patient soundness, blending traditional medicine with complementary modalities, such as acupuncture and chiropractic care.

Services at the clinic will include complex lameness diagnosis, advanced imaging, nonsurgical and surgical treatments, rehabilitation, and development of best practices for athletic wellness in collaboration with owners, referring veterinarians, trainers, farriers, and other health professionals. ■

BARN TALK: Pictured with the Hokie-Bird at the Youngkin Equine Soundness Clinic ribbon-cutting ceremony are Glenn and Suzanne Youngkin, distinguished friends of Virginia Tech; Michael Erskine, EMC director; Gregory Daniel, interim dean of the veterinary college; and Mike Moyer, Virginia Tech's associate vice president of development for colleges. ■

EXTRA, EXTRA!
READ ALL ABOUT IT.
For additional details, images, and videos related to the stories featured in Drillfield, go to vtmag.vt.edu.



HERSTORY: Professor Donna Dunay, chair of the International Archive of Women in Architecture, discusses a campaign to build the university's archive of works by female architects with Robert Ivy, executive vice president and chief executive officer of the American Institute of Architects, and Marlene Shade, associate principal of Dewberry Architects Inc.

RACING TO SAVE—AND CELEBRATE—THE WORK OF WOMEN ARCHITECTS

THE INTERNATIONAL ARCHIVE OF Women in Architecture (IAWA) at Virginia Tech is issuing an open call to women architects worldwide to submit a seminal design or drawing to the university's historical collection.

The campaign, dubbed "A Seminal Piece," is the latest in the IAWA's three-decades-long effort to capture and preserve the contributions of women in architecture who are underrepresented in the annals of history.

Housed in Newman Library's Special Collections, the IAWA contains more than 450 collections of pioneering female architects. A joint effort of University Libraries and the College of Architecture and Urban Studies, it is one of the only archives in the world dedicated solely to women architects.

The organization was founded in 1985 by the late architect and Professor Emerita Milka Bliznakov as a means of addressing the gap in women's architectural history and education. Today, the group is led

by Donna Dunay, G.T. Ward Professor of Architecture in Virginia Tech's School of Architecture + Design; Associate Professor of Architecture Paola Zellner Bassett; and Samantha Winn, collections archivist at Virginia Tech Special Collections, along with many others.

The archive boasts a distinguished international board of advisors; spans 47 countries, 17 languages, and two centuries; and draws students, architects, and scholars worldwide to gain a broader understanding of the built environment.

It also has created a network of architects united in sharing a lost legacy.

"The first generations of licensed female architects are passing away and their stories with them," Dunay noted. "The best way to honor these women is to ensure they don't fade into obscurity. We need to preserve their work so future generations appreciate the path they cleared and how they continue to influence our profession today." ■

ZUKA JOINS K-9 PROGRAM

THE VIRGINIA TECH POLICE

Department is pleased to announce the newest member of the force: Zuka, a 16-month-old German shepherd.

Zuka will provide apprehension and narcotic detection services.

Zuka's handler is Officer Jaret Reece, who has served in the K-9 program since 2009.

In 2002, the Virginia Tech Police Department was the first university police department in the state to establish a K-9 program.

The department currently has three K-9 teams actively engaged in the university's policing efforts. K-9 teams patrol campus and are responsible for sweeping Lane Stadium and other university facilities in advance of major events. Each of the dogs has specialized training that can include tracking suspects and missing people or searching for drugs or explosives. The K-9 teams also offer community demonstrations throughout the year.

"Our K-9 teams are an unmatched asset for advancing safety and security at Virginia Tech," said Virginia Tech Police Chief Kevin Foust. ■



PAW PATROL: Zuka is the newest member of the Virginia Tech Police Department's K-9 program.

PAOLA ZELLNER BASSETT, EW



PERMANENT PROVOST: Cyril Clarke, who since 2017 served as interim executive vice president and provost at Virginia Tech, assumed the role permanently in January.

“

I AM HONORED TO BE ABLE TO HELP VIRGINIA TECH SERVE THE COMMONWEALTH."

Cyril Clarke, provost

CLARKE NAMED PROVOST

CYRIL CLARKE HAS BEEN NAMED

Virginia Tech's executive vice president and provost following an international talent search. Clarke, who had served as interim provost and is the former dean of the Virginia-Maryland College of Veterinary Medicine, assumed the permanent role on Jan. 1.

"I am honored to have Cyril join us as the EVP and provost at such a pivotal time in our history," said Virginia Tech President Tim Sands. "It is leadership like Cyril's that will allow us to achieve our highest aspirations."

As chief academic officer and lead for the institution's academic enterprise, Clarke will continue to work closely with Sands, college deans, and campus administrators to advance cross-disciplinary initiatives, continue to build the research enterprise, and position Virginia Tech as a 21st-century global land-grant university.

"I am honored to be able to continue this collaborative work with faculty and academic leaders in every college and every department and to help Virginia Tech serve the commonwealth as we achieve global distinction," Clarke said.

The strength of the candidates who visited campus during the search "signaled the academic credibility and reputation of Virginia Tech," said Rosemary Blieszner, dean of the College of Liberal Arts and Human Sciences and Alumni Distinguished Professor, who chaired the search committee. "I am thrilled to have my fellow dean and colleague serve as Virginia Tech's next provost, knowing that Cyril is clearly the best in the country to lead us at this time."

Clarke joined Virginia Tech as dean of the Virginia-Maryland College of Veterinary Medicine in 2013. In that role, he launched a degree in public health, the college's first undergraduate degree program.

Clarke has served on the Board of Directors for the Association of American Veterinary Medical Colleges and is a past president of the American College of Veterinary Clinical Pharmacology. He is also a past member of the National Agricultural Research, Extension, Education, and Economics Advisory Board and the American Veterinary Medical Association Council on Education, the accrediting agency for veterinary medical education in North America.

A native of Johannesburg, South Africa, Clarke earned his professional veterinary degree from the University of Pretoria, South Africa, in 1981; a Ph.D. in veterinary pharmacology from Louisiana State University in 1987; and an M.S. in higher education from Oklahoma State University in 2000. He is certified as a Diplomate of the American College of Veterinary Clinical Pharmacology. ■

ROOM TO GROW

TUCKED AWAY AMID THE IMMACULATE landscaping of Virginia Tech's Turf-grass Research Center grows a garden. Although viewers from Southgate Drive might mistake the growth for an unmown patch of weeds, this garden is a haven for Indigenous plants, seed repatriation, and the building of community.

Established by Sam Cook, director of American Indian Studies, and John Galbraith, associate professor in the Department of Crop and Soil Environmental Sciences, the Indigenous garden was cultivated as part of a 2014 class. With steady guidance from elders Vicky Ferguson, a Monacan Indian and interpreter at Natural Bridge State Park, and Jeffrey Kirwan, professor emeritus and forestry Extension specialist in the College of Natural Resources and Environment, the garden has become not just a place to grow Native species but to cultivate relationships.

Sunflowers, Seminole pumpkins, patty pan squash, cushaw, cornfield beans, Cherokee purple tomatoes, and multiple varieties of potatoes propagate the green space alongside wilder "volunteer" species such as lamb's quarters and ground cherry.

At a special gathering last fall, members of the student organization, Native at Virginia Tech, alumni, and parents joined Kirwan and Mae Hey '17, an InclusiveVT faculty fellow, who is also a postdoctoral fellow in American Indian Studies, a faculty fellow with the Leadership and Social Change Residential College, and an Indigenous community liaison for Office for Inclusion and Diversity. The small group assisted with the harvest of Tutelo strawberry corn as part of a repatriation

project, "meaning it's a citizen returning to its homeland," Hey said. None of the seeds for the garden are purchased, but come from seed exchanges.

"We are keeping the traditions of the ancestors through sharing our seed relatives among our communities. This practice reminds us that the seeds are autonomous beings and gifts that coevolve with us, nurturing our wellness, rather than commodities that can be bought and exploited," said Hey.

A portion of the harvest is shared with local food banks through the New River Valley Glean Team.

In tandem with the creation of the American Indian and Indigenous Community Center in Squires Student Center, the garden has become a venue for an active, growing population of Native students. Together, the students are powering efforts to build a bigger Indigenous community at Virginia Tech by participating in outreach efforts to state tribes as well as organizing spring powwows in 2017 and 2018.

Lee Lovelace '09, tribal outreach liaison with undergraduate admissions, Hey, and students in Native at Virginia Tech travel around the state to visit Virginia tribes at festivals, powwows, and other events. The students build connections with Virginia tribes while also acting as ambassadors for Virginia Tech. By engaging with Native middle and high-schoolers during these visits, the students are not only ambassadors for the university, but also examples of the talented students that Tech attracts, modeling the college experience for young

people who may be the first from their families to attend college.

The effort reflects Virginia Tech's motto of *Ut Prosim* (That I May Serve), and the land-grant mission to serve the public.

Until recently, members of Virginia tribes had not been officially recognized by the federal government. Six Virginia tribes—the Chickahominy, Eastern Chickahominy, Upper Mattaponi, Rappahannock and Nansemond Tribes, and Monacan Indian Nation—were federally recognized in January 2018. The Pamunkey tribe was recognized in 2016.

Virginia Tech's rejuvenated outreach efforts honor those tribes and their long histories and address President Tim Sands' goal that 40 percent of Tech's student body be made up of underrepresented, first-generation, or lower-income students by 2022.

"Let's not forget the fact that we have 11 tribal communities in this state, as well as the fact that Tech sits on Monacan Nation land," said Melissa Faircloth, director of the American Indian and Indigenous Community Center, whose work as a Diversity Scholar led to the powwows at Virginia Tech. "Those students should feel like this is their university, that there is opportunity here for them."

As with the Indigenous garden amid the turf, these students are increasingly finding room to grow. ■ MA

DM



LET IT GROW: Mae Hey, InclusiveVT faculty fellow, collects seeds from various plants grown in the Indigenous garden including (above) those from the heads of sunflowers. (top right) Jeffrey Kirwan demonstrates winnowing, an agricultural method developed by ancient cultures to separate grain from chaff.



Margo Crutchfield

HOW TECH TICKS

THE ART

BEHIND THE EXHIBIT

FOR EACH OF THE MOSS ART CENTER'S ROUGHLY EIGHT SHOWS PER YEAR, MARGO CRUTCHFIELD AND EXHIBITION PROGRAM MANAGER MEGGIN HICKLIN OVERSEE THE INSTALLATION PROCESS THAT TRANSFORMS EMPTY GALLERIES AND HALLWAYS INTO SHOWCASES COMMUNICATING NOT ONLY THE ART, BUT THE VISIONS AND WORK PROCESSES OF THE ARTISTS.

"WHAT I LIKE ABOUT IT IS IT'S EVERYTHING FROM A TO Z. YOU'RE DOING EVERYTHING FROM PAINTING WALLS TO UNPACKING WORKS OF ART TO EXAMINING THEM AND FIGURING OUT WHERE THE WALLS GO," CRUTCHFIELD SAID. "BEING ABLE TO INVENT AN EXHIBITION AND THEN MAKE IT HAPPEN IS PRETTY THRILLING." ■ TW

LOREN SKINKER, EW

THE BIG PICTURE: (top right) Justin Hurt '07 and Bo Menees, owners of Signspot, install Diane Cook and Len Jenshel's Emancipation Oak, 2014, an expansive digital image on phototext. (at right) Joe Kelley, head preparator and art handler, unpacks art for an upcoming show. (opposite) Preparator Dominique Francesca takes down Leah Sobsey's site-specific installation of cyanotype butterflies in the fall 2018 exhibition "Swarm."



MICHAEL FOLTA

“

IT'S A VERY SOCIAL THING. OPENINGS ARE ALWAYS INVIGORATING. YOU HAVE WONDERFUL ART ON VIEW, AND YOUR COMMUNITY IS THERE TO CELEBRATE WITH THE ARTISTS.”

Margo Crutchfield, curator-at-large



INSPIRED

To watch a video about art installations at Moss Arts Center, go to vtmag.vt.edu.

2

YEARS OUT

EACH EXHIBITION STARTS WITH THE CURATOR DEVELOPING A CONCEPT THAT PRECEDES THE GALLERY DEBUT BY AT LEAST TWO YEARS. CRUTCHFIELD RESEARCHES WORKS AND ARTISTS, CONCEPTUALIZING WAYS THEY MIGHT FIT INTO LARGER DISPLAYS. SHOWS OFTEN DRAW ON SOME UNIFYING QUALITY, SUCH AS STYLE OF ART, TOPIC, OR ISSUE. THE CENTER'S MOST RECENT EXHIBITION, "ARBOREAL," IS CENTERED ON THE SIGNIFICANCE OF TREES AND THEIR SYMBOLISM.

"Generally, each exhibition takes more than a year to put together," Crutchfield said. "That's doing all the research. That's reading all the books, and seeing as much art as possible in artists' studios, galleries, and museums."

1

YEAR OUT

ONCE CRUTCHFIELD BEGINS TO IDENTIFY THE DESIRED PIECES FOR AN EXHIBITION, THE "HUNT" BEGINS.

"Every object in an exhibition comes from a museum, a collector, the artist's studio, or from some other organization, such as corporate art collections. So, you have to go out and find the object and then orchestrate borrowing them, and that can be a complicated dance. But basically, you have to talk people out of their art and convince them to live without it for the duration of the exhibition," Crutchfield said.

4

MONTHS OUT

THE PROCESS OF SECURING THE LOANED PIECES AND DESIGNING THE EXHIBITION CONTINUES AS OPENING DAY DRAWS NEARER, AS DOES THE RESEARCH TO BEGIN TO GENERATE THE PROMOTIONAL MATERIAL, WHICH INCLUDES MAILERS, PROGRAMS, AND EXHIBITION BROCHURES.

"It's important to understand each work of art and understand what the artist is doing in order to fit it into a theme," Crutchfield said. "Writing the curatorial essays for the exhibition brochures, I think, is the hardest part because it is an intellectual exercise that draws on your knowledge of art. It takes the most brain power."

3

WEEKS OUT

THE REAL FUN BEGINS AS THE WORKS FOR THE EXHIBITION BEGIN TO COME IN, OFTEN IN LARGE SHIPPING CRATES CONSTRUCTED BY PROFESSIONAL ART SHIPPING COMPANIES.

"Unwrapping the crates is like unwrapping a present," Crutchfield said. "It's always fascinating! We work with a wonderful team of preparators, including Joe Kelly, Chris Cobb, Dominique Francesca, and members of the Moss Arts Center production team, to present the art in the most visually appealing way."

THE TAKE DOWN



NOW IN REVERSE



A FAMILY AFFAIR

FIVE YEARS AGO, NOBODY IN THE Kros family had a tie to Hokie tennis, Virginia Tech, or Blacksburg.

Today, brothers Jason '19 and Ryan Kros '21 play for the Hokies, who have gone to the NCAAs two of Jason's three years. And while Hokie head tennis coach Jim Thompson tutors the sibling duo, father Todd Kros coaches Thompson's son, Frank, who won the state 4A singles and doubles titles in 2018 as a Blacksburg High School freshman. Not one to be left out, mother Rachel Kros applies her knowledge of the United States Tennis Association (USTA) to administrative and organizational work for area junior tennis players.

It's an unusual situation, but Thompson couldn't be more pleased. "They've [the parents] been super supportive of what we do and been helpful whenever they can," he said.

Jason, now ranked 30th in the nation among college players, is working for a shot at pro tennis. Ryan, a member of the Corps of Cadets, plans a military career, just like his father.

Jason and Ryan got into tennis when they were 7 and 5 after finding their dad's 14-year-old racquets and balls during a move from Ft. Leavenworth, Kansas, to California. Todd Kros played tennis at Rice University before pursuing an Army career. He retired as a lieutenant colonel.

At the boys' request, Todd started teaching them to play. By the time Todd retired from the military and the family moved to Northern Virginia, the brothers were training at the elite USTA

regional training center in College Park, Maryland. Though they didn't play often for their high school, W.T. Woodson, they won a state championship as doubles partners in 2015.

Virginia Tech wasn't on Jason's post-high school list until he and his mom happened through during a college visitation trip, and he started thinking about playing tennis in a competitive league like the ACC. Thumbs-up research by Rachel and encouragement from a friend already on the team sealed it.

"When I met with Coach Thompson, everything just seemed like it was going to be a comfortable experience for me," Jason said. "Plus, at that point we had one of the best teams in the country, and it was an opportunity for me to play with them."

Two years later, Ryan narrowed his search to West Point and Virginia Tech. "I picked Virginia Tech because you only get to play college tennis once, and I wanted to play in the ACC," he said. "[And] it's

one of the top ROTC programs in the country, so I knew I'd be getting a good stepping stone into the Army."

Once Ryan made his decision, the parents packed up and headed for Blacksburg. "We left about a month before he graduated [high school], and he had to stay with friends," Todd said. "Everybody there thought I was nuts."

It doesn't seem so nutty now. Jason's game has improved tremendously. "A lot of guys want to play pro, but he's put himself in a position where he has a shot to do that," Thompson said.

Ryan has learned to juggle his corps duties, academics, and Division I tennis. "Once I learned to manage my time—I wouldn't say it's a breeze—but it's nothing unmanageable," he said.

And Todd and Rachel have found a home.

"I've been thrilled. ... It's the experience of a lifetime," Todd said. ■ RL

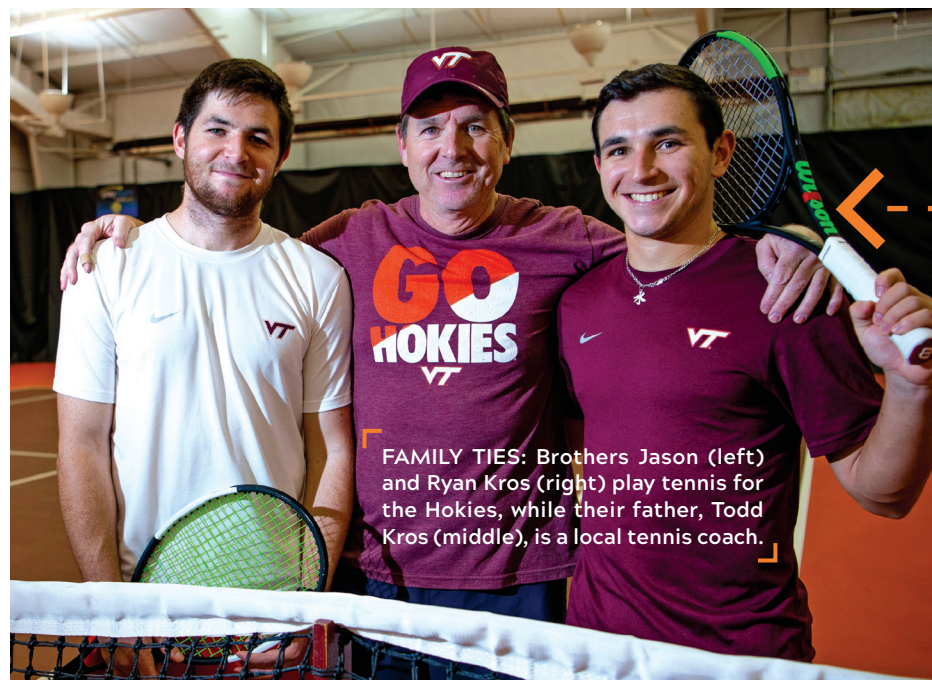

FAMILY TIES: Brothers Jason (left) and Ryan Kros (right) play tennis for the Hokies, while their father, Todd Kros (middle), is a local tennis coach.

QUESTION

POWER DOWN TO REBOOT

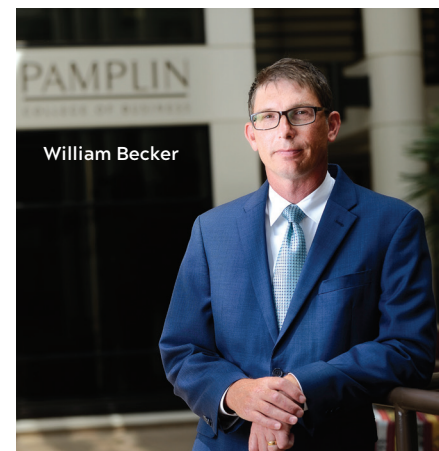

YOUR DEVICES MAY SEEM LIKE a fun extension of your social life, but unchecked, continuous connectivity can become an intrusion, upsetting the work-life balance and negatively influencing your personal health and relationships.

William Becker, associate professor of management for the Pamplin College of Business in Northern Virginia, recently completed his third study on the negative health impacts of "after-hours" email.

HOW COMMON IS THE PROBLEM OF "AFTER-HOURS" EMAILS?

"I think it's becoming a bigger and bigger issue. This is now our third study, with a survey of over 4,000 people, and negative effects have been identified across all studies. It really affects all kinds of industries. It affects genders equally, older, younger workers—it's a common problem the world is struggling with."

DO YOU THINK IT'S POSSIBLE TO REVERSE THE TREND?

"You can't put the genie back in the bottle, but what our research suggests is that you can find ways to minimize the negative impacts, especially for work-related emails. In our personal lives, email becomes an extension of the connection to Snapchat, Instagram, Facebook, but email is fundamentally different. Whenever you look at your work email, your brain actually shifts over to work mode. If you continue to check your email, you get stuck in work mode, and your work self isn't necessarily the best you. Your work self is usually much more competitive and serious, and it keeps you from enjoying your off-work time."

WHAT WOULD THE POSSIBLE SOLUTIONS LOOK LIKE?

"We think that the real solutions will come from leaders, at all levels, recognizing the problem and setting the example themselves: disconnecting and not sending emails at all hours during the night."

WHAT CAN AN AFFECTED EMPLOYEE DO TO MANAGE THIS ISSUE?

"Initiate discussions with your supervisor not only about the requirements of your position, but also ask for feedback on how to recuperate and disengage from work. Most supervisors want you to be responsive, but they don't want you to be constantly checking in either. We may overestimate their expectations." ■

Brendan Coffey, a junior majoring in multimedia journalism, is an intern with Virginia Tech Magazine.





IN MEMORIAM

SARAH MITCHELL

THE RAIN STOPPED LESS THAN AN hour before the Virginia Tech Corps of Cadets and the campus community gathered Nov. 9, 2018, to honor the addition of the name of U.S. Navy Ensign Sarah Mitchell '17 to the Ut Prosim pylon.

Mitchell, of Feasterville, Pennsylvania, died July 8, 2018, during a Naval training exercise in the Red Sea. Hers is the 432nd name—and the first of a woman—on the Pylons.

Mitchell earned a degree in biochemistry and minors in chemistry and leadership studies. She commissioned in May 2017 and reported a month later to the guided-missile destroyer USS Jason Dunham.

Command Sgt. Maj. Dan Willey, the senior enlisted advisor for the corps' 1st Battalion, worked closely with Mitchell, especially when she commanded Alpha Company. An excerpt of his remarks from the Nov. 9 ceremony follow.

Every once in a while, a person comes into our lives that will impact us forever. These people are rare, very rare. As a cadet, Sarah was my one in a thousand.

"Where do they come from? What inspires these young passionate patriots to stand their watch in uniform for this great nation? Sarah could have done anything in life, and she would have been exceptional at it. She chose service as a naval officer.

"Service to others was natural to Sarah. She cared about everyone and everything. Here in the Corps of Cadets, she sought out the toughest of jobs. Duties that would put her directly in position to lead and make an impact.

"I liked to say that her battery seemed to have two positive terminals. She was always in a great mood and always had a smile. She loved to compete, and she loved to win. As the captain of the corps basketball team, Sarah led them

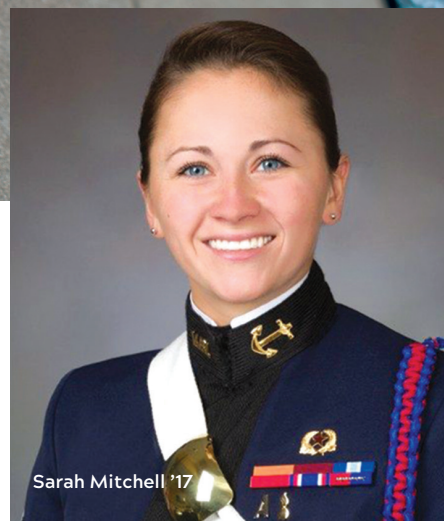

Sarah Mitchell '17

to a national championship. The other players on both the men's and women's teams knew her as 'the floor general,' as she would always find a way to rally the team to yet another victory.

"Sarah's leadership style was quite unique. She mastered the art of speaking to people and not at them. She could often be found sitting in a quiet corner of the dorm away from the spotlight of the corps, softly coaching and mentoring a struggling cadet.

"It is very hard to say goodbye to a national treasure. All of you in attendance today, please know that the corps stands before you in this weather, not because they have to, but because they want to." ■

Shay Barnhart is the communications director for the Corps of Cadets.

WHAT'S IN IT?



STRIKING A CHORD

INSTALLING GIANT NETS ALONG hillsides and mountaintops to catch water out of thin air sounds more like folly than science. However, fog harvesting has become an important avenue to clean water for many who live in arid and semi-arid climates around the world.

A passive, durable, and effective method of water collection, fog harvesting consists of catching the microscopic droplets of water suspended in the wind

that make up fog. Unfortunately, fog nets have long posed a dual constraint problem: If holes in the mesh are too large, water droplets pass through without catching on wires. If the mesh is too fine, the nets collect more water, but droplets may obstruct the holes, creating a clog that prohibits water collection.

In the spring of 2018, an interdisciplinary research team at Virginia Tech improved the traditional design of fog nets, tripling their collection capacity. The researchers

removed the horizontal wires of the net, resulting in a vertical array—dubbed a "fog harp"—that caught more water and alleviated clogging. To test the design, the scientists constructed small-scale vertical wire arrays and placed them inside an environmental chamber with artificial fog.

The team has since constructed a larger prototype of the fog harp and continues to test it in various field settings. ■ MA

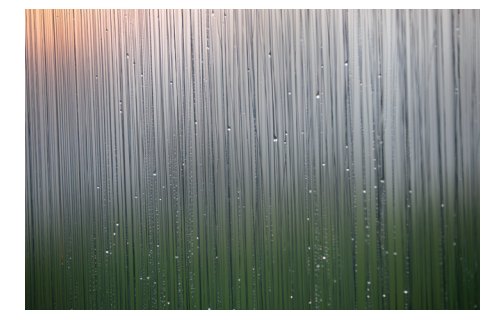
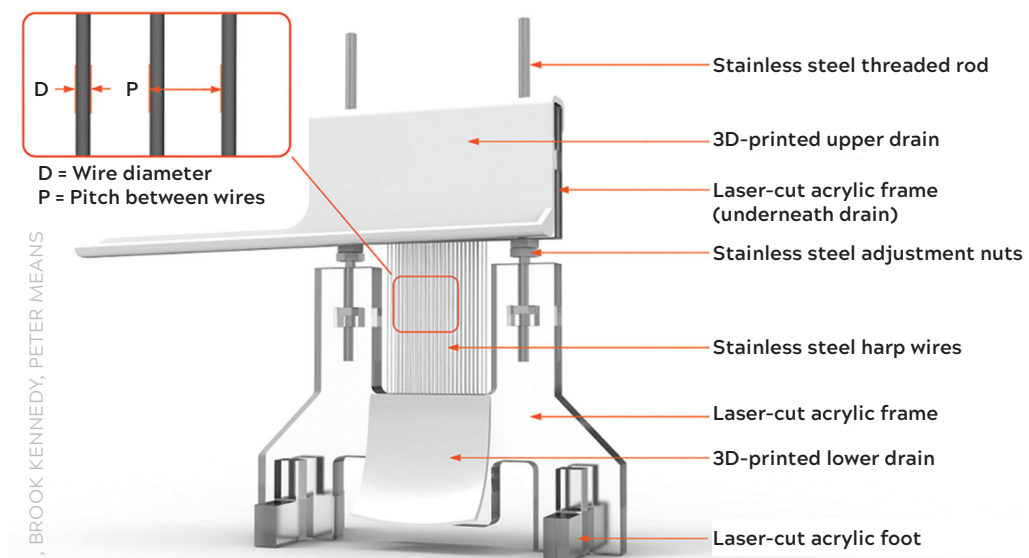

Field tested: (top) Jonathan Boreyko (left), an assistant professor in the College of Engineering, and Brook Kennedy (right), an associate professor in the College of Architecture and Urban Studies, set up a full-scale prototype of the fog harp at Blacksburg's Heritage Community Park. (above) Kennedy has described the vertical array of wires as the fog harp's "secret sauce."

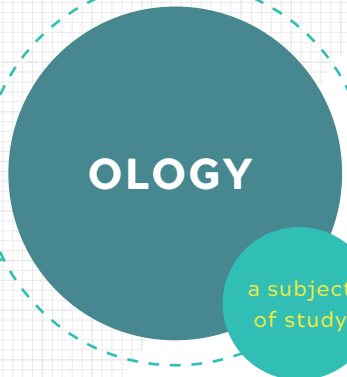

PERUVIAN PERSPECTIVE

IN PERU, THE LANDSCAPE IS OLDER THAN THE SOUND OF BELLS AND SNOW on mountains, but modern-day Peruvian life commands attention.

During 10 days in July 2018, in this vast, knitted-together country of coasts, mountains, and jungles, 14 undergraduates from Virginia Tech and the University of Piura learned to apply the techniques of behavioral economics to resolve problems that ranged from deforestation and accumulating heaps of waste to child mortality and flagging schools.

The students listened to lectures, visited a flood-ravaged town, learned about deforestation, conducted a survey in a small village (after walking an hour to get there), and spent a magical hour atop the Andes.

The culmination of the experience involved working in teams to craft a pilot intervention that would cost a theoretical \$100,000 to implement, followed by competitively pitching those change-the-world ideas to professors Marcos Agurto of the University of Piura and Sheryl Ball of the Department of Economics in Virginia Tech's College of Science.

“

IN THE FUTURE I CAN BETTER PARTICIPATE IN MY LOCAL AND CENTRAL GOVERNMENTS. I CAN PROPOSE BETTER POLICIES. **WHAT I'M LEARNING HAS HELPED ME REALIZE HOW THE WORLD CAN WORK BETTER.**”

Jose Luis Herrera Hinojosa, student

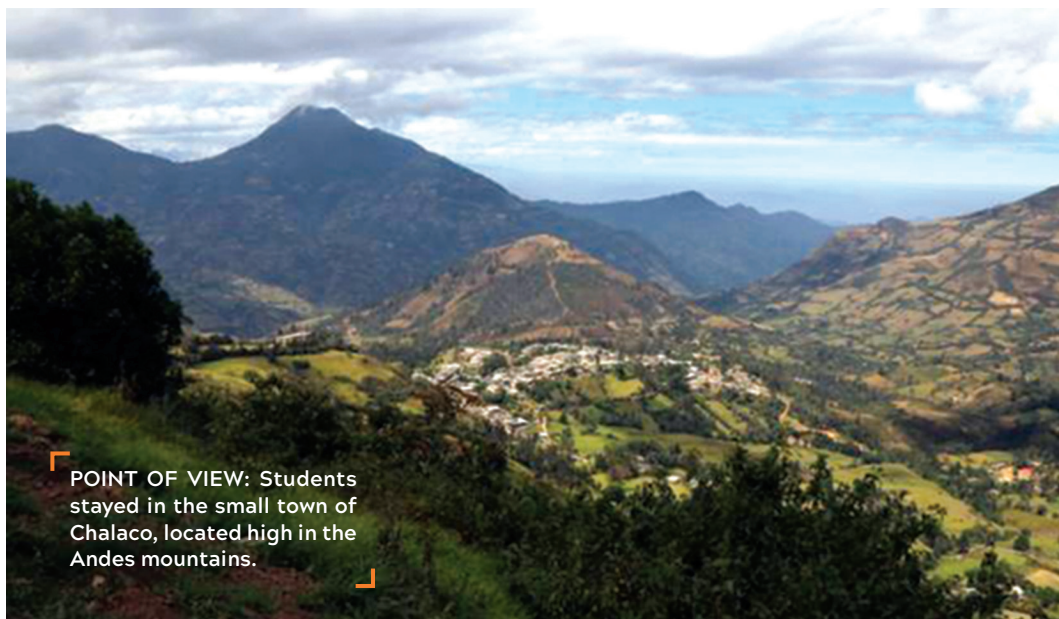

POINT OF VIEW: Students stayed in the small town of Chalaco, located high in the Andes mountains.



THUMBS UP: The student group, which included Alessandra Hidalgo, Hannah Looney, and Jose Luis Herrera Hinojosa, hiked several miles to meet with residents of a small village near Chalaco, Peru.

The students were asked to consider: Is aid to developing countries good or bad? Does it create dependency? Do policymakers offer expert help and then simply hope the situation gets better? Or do they stand by, do nothing, and watch problems play out? Economists must find ways, as Agurto put it, “to know what works, and why.”

Agurto, who has taught as an adjunct at Virginia Tech, stressed the concept of listening before designing answers to problems. He also explained the need for control groups and randomization—essential to knowing whether an “intervention” has worked.

The students had two days to plan and prepare their talks. One team, tackling low-performing schools, devised ways for teachers to network. Another team looked for ways that seasonal workers might find productive year-round employment.

“We are not looking for a perfect presentation, but we want to see whether the intuition is there,” Agurto said. “The

small taste that we are giving them about economic policy—that’s basically a chain of starting [to think] about a problem.”

Jose Luis Herrera Hinojosa, a student from the University of Piura, previously doubted whether becoming an economist would enable him to contribute to society. He now understands that even a simple intervention—say, a plan to encourage vaccination in children by giving their parents a reward—can improve lives.

“We can do things—we can propose the right things, things that we are sure are going to be good,” he said. Agurto’s enthusiasm buoying him, he added: “In the future I can better participate in my local and central governments. I can propose better policies. What I’m learning has helped me realize how the world can work better.” ■

Andrea Brunais is the director of communications for Outreach and International Affairs.

HOW IT CAME ABOUT: PROGRAMS AND PARTNERS

Formally known as VT-UDEP Economics Lab: Experiment-Driven Policy Making in Peru, the program offers educational opportunities in behavioral and experimental economics on Virginia Tech’s Blacksburg campus as well in Lima and Piura in Peru.

Funding for the venture came from several sources, including Virginia Tech’s Center for Instructional Development and Educational Research and the Global Education Office, part of Outreach and International Affairs, as well as a \$25,000 grant from the 100,000 Strong in the Americas Innovation Fund, part of the nonprofit Partners of The Americas.

POSTCARDS FROM PERU

For more photos and personal accounts of the students’ experiences, visit vtmag.vt.edu.



Jose Luis Herrera Hinojosa

DRIVING

INNOVATION CAMPUS
HELPS ATTRACT AMAZON
TO NORTHERN VIRGINIA



By Travis Williams

PROGRESS

VIRGINIA TECH HAS SET THE BAR AS A LEADING LAND-GRANT UNIVERSITY SINCE ITS FOUNDING. WHEN THE SCHOOL LAUNCHED IN 1872, MEETING THE MISSION MEANT OFFERING A CURRICULUM THAT PROVIDED FUTURE FARMERS, TRADE WORKERS, AND SOLDIERS WITH PRACTICAL KNOWLEDGE AND PERSONAL EDUCATION AROUND TOPICS LIKE HYGIENE, HEALTH, AND MANNERS. TODAY, THAT DRIVE TO SERVE MEANS PARTNERING WITH BUSINESS AND INDUSTRY TO ACCELERATE WORKFORCE DEVELOPMENT AND TECHNOLOGY.

When Amazon announced it was seeking a second headquarters, hundreds of localities rolled out the red carpet in an attempt to lure the company.

Virginia, however, had the foresight and courage to take a different approach, including leveraging the mission of its largest land-grant university as part of a comprehensive \$1.1 billion higher education package.

“The state asked, ‘How can we create an enabling environment that is an attractive place for companies like Amazon to operate?’” said Brandy Salmon, Virginia Tech’s associate vice president for innovation and partnerships. “It was an opportunity to drive diversification and innovation in the commonwealth with a direct investment back into the state.”

A key part of the answer, and the deal that ultimately landed Amazon in Arlington, was Virginia Tech’s bold vision to develop the Innovation Campus to serve as a leading magnet for high-tech talent. The proposed 1 million-square-foot graduate campus in Alexandria will transform and sustain Northern Virginia as a leading magnet for tech talent and innovation—with room to grow, adapt, and evolve as the market changes.

“The rigorous programs we launch and the powerful research we generate will help drive the innovation economy,” said Salmon, the campus’ founding managing director. “Together with partners in industry, government, and education, we will cement Virginia as a world leader for the information age.”

During the 14-month proposal process, which was quietly navigated by the Virginia Economic Development Partnership, both the company and state realized the benefits of tapping into the university’s core purpose of serving the citizens of the commonwealth.



AMAZON'S CHALLENGE PROVIDED THE CATALYST TO ACCELERATE A PLAN THAT WE ALREADY HAD IN PLACE BY BRINGING TOGETHER VIRGINIA LEADERS WHO ARE COMMITTED TO THE VISION TO TRANSFORM AND SUSTAIN THE COMMONWEALTH AS A LEADING MAGNET FOR TECH TALENT AND INNOVATION—WITH ROOM TO GROW, ADAPT, AND EVOLVE."

TIM SANDS,
VIRGINIA TECH PRESIDENT

"The Innovation Campus helps Virginia Tech live out its mission to support economic growth," said Theresa Mayer, Vice President for research and innovation. "As a research land-grant university, it is critical to translate research and discoveries into the marketplace where they can have tangible impact."

For Amazon, which already employs hundreds of Hokies, that meant the assurance of pipelines producing tomorrow's best workers and technology today. It meant benefiting from Virginia Tech's track record of molding students with disciplinary depth complemented by interdisciplinary know-how. It meant tapping into the university's cutting-edge research ready to be developed for commercialization.

For Virginia, the Innovation Campus meant the development of a community of quality talent, innovation, and infrastructure, which would not only serve Amazon's needs but would make the state a drastically more attractive landing spot for other existing companies and future startups.

"Virginia's biggest employment growth opportunity in the years ahead will be in tech—from artificial intelligence to cloud computing to cybersecurity, and everything in between," said Stephen Moret, president and CEO of the Virginia Economic Development Partnership. "Our success in growing the tech sector will be inextricably linked to our success in developing, attracting, and retaining world-class tech talent. [The] announcements by Amazon and Virginia Tech highlight just how important higher education is to that equation."

As a result, not only will the company's expected need for 25,000 employees provide opportunities in Virginia, but the project as a whole will attract other businesses and firms needing to fill their rosters.

In Virginia Tech, the state and company found a qualified partner who was willing to step forward and had a blueprint in place already to expand the university's work in the greater Washington, D.C., area.

"Amazon's challenge provided the catalyst to accelerate a plan that we already had in place," said Virginia Tech

President Tim Sands, "by bringing together Virginia leaders who are committed to the vision to transform and sustain the commonwealth as a leading magnet for tech talent and innovation—with room to grow, adapt, and evolve."

The \$1 billion campus will be constructed on U.S. Route 1 near Potomac Yard and will triple the university's footprint in Northern Virginia, which already includes seven facilities. It will include:

- 300,000 square feet of academic space and research and development facilities.
- 250,000 square feet of partner space dedicated to startups and corporate facilities.
- 350,000 square feet of housing space for students and faculty.
- 100,000 square feet of retail and support spaces.

The campus will bring together hundreds of new graduate students, dozens of new faculty members, and numerous industry partners. In Blacksburg, Virginia Tech will increase undergraduate enrollment in computer science, computer engineering, software engineering, and related disciplines by 2,000 over the next eight years.

But the impact of the Innovation Campus will not be limited to the timeline of a physical structure.

"We will not wait until the campus is built, because the need for talent exists right now," Sands said.

The first master's degree students will enroll in either existing locations or temporary space with the campus hosting a total of 500 master's degree students within five years and, at scale, enrolling 750 master's degree candidates and training hundreds of doctoral students and post-doctoral fellows.

That news has stirred excitement among Hokies across the country and has many already exploring getting involved.

"I was really excited at how soon this is happening," said Mahna Ghafari, who returned home to Fairfax after earning a degree in computational modeling and data analytics in May 2017.

"I had already had thoughts of doing grad school, but I didn't know where," Ghafari said. "When Virginia Tech announced they were coming here, I thought, 'Oh my gosh, it's meant to be.'"

The Innovation Campus' degree programs and research opportunities will focus on computer sciences and software engineering, while offering specializations in high-demand areas, including data sciences; analytics and collective decisions; security and the internet of things; and technology and policy.

Such disciplines might be the first to come to mind in relation to Amazon, but they are far from an all-inclusive list of opportunities with an e-commerce pioneer, which relies on workers of all backgrounds who cross disciplinary boundaries in ways that are already staples of the Virginia Tech learning environment.

"At Virginia Tech, we're already bringing together technology and creativity to explore and innovate at the boundaries of the sciences, engineering, the arts, and design," said Ben Knapp, founding director of the Institute for Creativity, Arts, and Technology (ICAT). "We have the faculty and facilities to provide students with the cross-disciplinary education necessary to succeed in a company like Amazon."

ICAT provides an example of Hokies learning in situations that mirror those of real-world companies. The university's thematic institutes and transdisciplinary communities, the Destination Areas, also boast of environments that immerse students in the types of academically diverse situations that replicate the working world. These efforts merge such disciplines as art, design, and humanities with STEM concentrations to produce graduates who understand the value of incorporating different perspectives into decision-making.

This experiential-driven learning means Hokies of all disciplines are poised to step out of the university setting and into the type of workforce Amazon requires to thrive. And likewise, the cross-disciplinary demands of the retailer will fuel the university culture producing that workforce.

Virginia Tech's history is highlighted by transformational events aimed to meet the ever-evolving needs of our world. And while the Innovation Campus is definitely one of the most recent, it's guided by the same age-old principles on which the university was founded in 1872.

"While needs and challenges have changed greatly over the course of the university's nearly century-and-a-half history, our commitment to make an impact has not," said Dennis Treacy '78, Virginia Tech Board of Visitors rector. "Creating an Innovation Campus is right in line with Virginia Tech's character—our drive to serve."

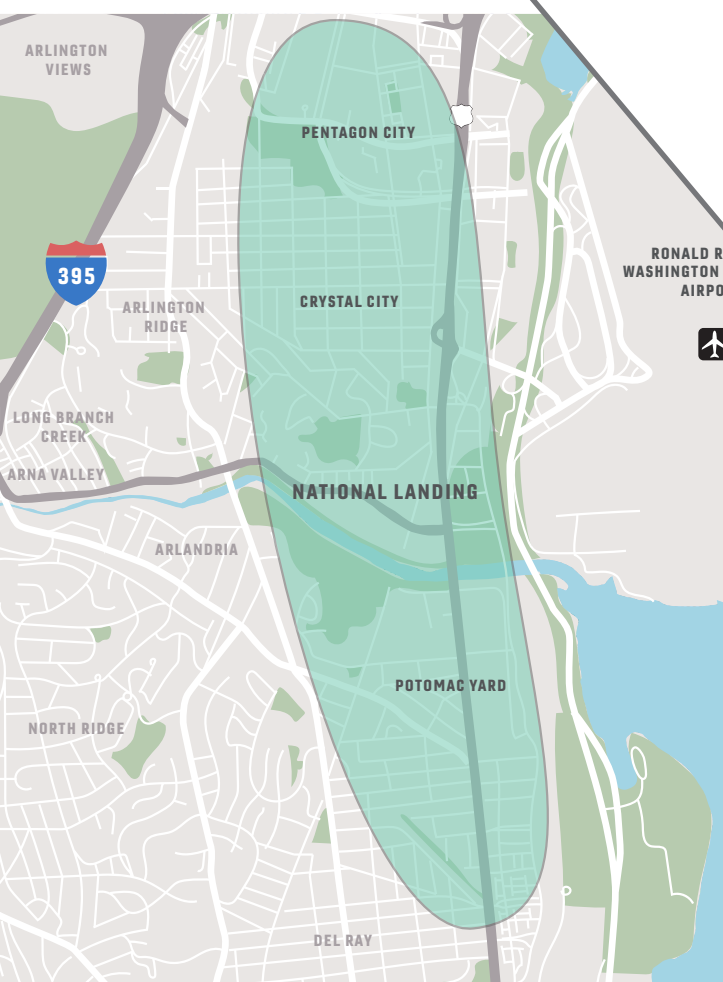

AMAZON'S HQ2 AND THE VIRGINIA TECH INNOVATION CAMPUS WILL LOCATE IN NATIONAL LANDING, A NEWLY BRANDED NEIGHBORHOOD THAT ENCOMPASSES PARTS OF PENTAGON CITY AND CRYSTAL CITY IN ARLINGTON, VIRGINIA, AND POTOMAC YARD IN ALEXANDRIA, VIRGINIA.

LEADING

FRALIN BIOMEDICAL
RESEARCH INSTITUTE AT VTC
ROANOKE, VIRGINIA

RESEARCH



By Mason Adams and John Pastor

THE EARLY UNIVERSITY IN BLACKSBURG HARNESSSED THE POWER OF RESEARCH, MAKING OUTCOMES ACCESSIBLE TO THE LARGELY AGRARIAN POPULATION THAT WAS TEETERING ON THE CUSP OF AN INDUSTRIAL REVOLUTION THAT WOULD CHANGE THEIR WAY OF LIFE. TODAY, VIRGINIA'S GLOBAL LAND-GRANT UNIVERSITY LOOKS A LITTLE DIFFERENT THAN IT DID AT ITS FOUNDING, SUPPORTING RESEARCH AND LEARNING ON CAMPUSES FROM BLACKSBURG TO WASHINGTON, D.C.

IN ROANOKE, SCIENTISTS ARE ENGAGED IN MEDICAL STUDIES DESIGNED TO ADDRESS HEALTH CHALLENGES AND CHANGE LIVES.

Hokies thrive in new frontiers, whether at the forefront of scientific research, on the cusp of technology development, or at the cutting edge of reinventing spaces. The newly renamed Fralin Biomedical Research Institute at VTC intersects all three.

That trifecta inspired the Horace G. Fralin Charitable Trust and Heywood and Cynthia Fralin to announce, in December 2018, a \$50 million gift—the largest gift in Virginia Tech history—to the successful enterprise, catapulting it to the next level.

The institute, first known as the Virginia Tech Carilion Research Institute, was created around a bold yet straight-forward vision: Gather top-tier biomedical research talent, arm them with the resources of a major research university and an enterprising health care system, give them the freedom to innovate, and stand back.

The institute thrived.

Eight years later, the research institute has become a setting for intense, interdisciplinary collaboration among creative, entrepreneurial scientists, and has provided access to state-of-the-art molecular biology, imaging, behavioral, and computational facilities. The resulting partnerships have generated discoveries and intellectual properties that are fueling diverse biomedical-sector startups.

Located near the Roanoke River in a place once considered a blighted landscape of industrial decay, the Virginia Tech Carilion Academic Health Center is revitalizing the South Jefferson Corridor and helping transform the Roanoke Valley economy. Seemingly overnight, Roanoke has transcended its railroad roots to become known as a science-centric outdoor mountain city that's become a destination for young professionals.



"SOME 10 YEARS AGO THIS WAS AN AGING INDUSTRIAL DISTRICT. TODAY, IT'S EXACTLY THE TYPE OF THRIVING, KNOWLEDGE-ECONOMY ENVIRONMENT THAT CITIES ALL OVER OUR NATION ARE STRIVING TO DEVELOP."

MICHAEL J. FRIEDLANDER,
VICE PRESIDENT FOR HEALTH SCIENCES
AND TECHNOLOGY AND EXECUTIVE
DIRECTOR OF THE FRALIN BIOMEDICAL
RESEARCH INSTITUTE AT VTC

The Fralin Biomedical Research Institute and the Virginia Tech Carilion School of Medicine anchor the Virginia Tech Carilion Health Sciences and Technology Campus and provide the foundation for the rapidly growing Roanoke Innovation Corridor.

Now, the \$50 million gift from the Horace G. Fralin Charitable Trust and Heywood and Cynthia Fralin is enabling the research institute to take a giant leap forward.

"Supporting an academic health center will help to raise the income levels of all of the citizens of the Roanoke Valley, and it will help change the future of Roanoke," said Heywood Fralin. "In fact, an argument can be made that the development of an academic health center here will have far more impact than the location of the Norfolk and Western offices here many years ago."

An academic health center comprises all health-related components of a university. It is typically affiliated with a health system.

The location of the railroad offices in the early 1880s launched Roanoke as a city. That Fralin would suggest the Academic Health Center might create more long-term impact than Roanoke's founding industry speaks to his belief in the unlimited potential of higher education when put to work for good in the right place at the right time.

Michael J. Friedlander, Virginia Tech's vice president for health sciences and technology and the executive director of the Fralin Biomedical Research Institute, called it "an amazing story of rejuvenation and discovery happening in Roanoke right now."

"Some 10 years ago, this was an aging industrial district," Friedlander said. "Today, it's exactly the type of thriving, knowledge-economy environment that cities all over our nation are striving to develop. The number of people working here on the VTC Health Sciences and Technology Campus is approaching 2,000—and projected to increase to over 5,000 within a few short years."

When combined with the university's growth in the Northern Virginia and a recent commitment to build a \$1 billion Innovation Campus in Alexandria, the Fralin Biomedical Research Institute solidifies

Virginia Tech's role as a transformative force.

Elevating its profile in biomedical discovery further directs the university's research prowess and *Ut Prosim* (That I May Serve) ethic toward society's most pressing challenges and promising arenas for discovery.

"Virginia Tech exists to improve lives and communities by using knowledge to solve problems, and some of humanity's greatest challenges exist in the realm of biomedical science," said Tim Sands, Virginia Tech president. "Discoveries in this field save lives and improve the quality of life. They will change the world in which our children and grandchildren will live. There is no better or more powerful way to serve humanity."

The renaming recognizes the Fralin family's commitment to support the institute's fundamental work: to make scientific discoveries, generate innovations, improve health through biomedical research, and build the state's biotech economy.

The Fralin commitment is a testament to the world-class quality of the institute's faculty members, who are widely regarded as scientific leaders.

"When I was a doctoral student at Stony Brook University, it was important to be associated with a named institute or named college department," said Gregorio Valdez, an associate professor at the Fralin Biomedical Research Institute and the Department of Biological Sciences in the Virginia Tech College of Science. "It is very motivational to know people recognize the importance of your work and are eager to commit resources to help. It is exciting to see that happening here in our institute."

The \$50 million gift will fuel a recruiting blitz for top international biomedical researchers, which is reflective of the organization's launch strategy in 2010. The institute quickly became recognized for having assembled some of the nation's top scientific talent, including faculty, staff, and students, and for accomplishments in multiple areas:

- Diagnosis and treatment of addiction and substance abuse in adolescents and adults, ranging from opioids to tobacco and alcohol.
- A new form of intensive child neurorehabilitation to treat the devastating consequences of neonatal stroke, including cerebral palsy.
- Technological innovations in interactive multi-subject and real-time human functional

brain imaging with the parallel development of the new field of computational psychiatry.

- A revolutionary paradigm for understanding how electrical signaling occurs in the human heart and identification of new targets for treating disturbances of heart rhythm in order to reduce the likelihood of sudden cardiac death.
- Several new strategies for treating the deadliest form of brain cancer in humans and in companion animals.
- The first elucidation of structural deformity in the molecule that causes a pernicious form of breast cancer.
- A pivotal new insight into the origins of memory cells in the immune system to fight infection and mediate immunity through vaccination.

As the institute grew, those strategic areas evolved. Today, the research efforts target cardiovascular science, neuroscience, cancer, immunology and infection, and regeneration and rehabilitation.

"These are the types of health challenges that we all face every day, right here in Roanoke, throughout our state, nation, and the world," Friedlander said. "And we are making real progress to lessen the incidence of the occurrence of those disorders, to effectively treat them when they do occur, and to achieve healthier lives for children, adults, and the elderly."

Several recent discoveries have led to patents that are centerpieces of spin-off companies, including a brain cancer stem cell therapeutic and a diagnostic screen for alcohol abuse risk. Both have won highly competitive federal technology transfer business awards.

Although the precise outcomes remain to be discovered, certain facts are indisputable: The Fralin Biomedical Research Institute will continue to increase development of intellectual property, to commercialize discoveries through startup businesses, and to grow an already strong portfolio of partnerships with industry. The outcomes will propel innovation from the laboratory to the clinic to the community. And the results will change lives.

MEDICALLY SPEAKING: Research studies at the Fralin Biomedical Research Institute at VTC advance medical discoveries to improve health and change lives.



DAVID HUNGATE

BUILDING

FUTUREHAUS
BLACKSBURG, VIRGINIA,
DUBAI, AND BEYOND

FUTURES



By Erica Corder and Travis Williams

NEARLY 150 YEARS HAVE PASSED SINCE THE FIRST STUDENT ENROLLED AT VIRGINIA TECH. THE NEEDS OF THE WORLD HAVE SHIFTED. TECHNOLOGY HAS ADVANCED. AND THE DEMAND FOR CREATIVE PROBLEM-SOLVING HAS GROWN EXPONENTIALLY. IN 2019, OUR WORLD-CLASS FACULTY ENGAGES WITH STUDENTS NOT ONLY INSIDE TRADITIONAL CLASSROOMS, BUT ALSO IN SWAMPS, URBAN NEIGHBORHOODS, AND ACROSS INTERNATIONAL BOUNDARIES. STUDENTS COLLABORATE ACROSS THE ACADEMIC SPECTRUM, CREATING THE FUTURE THROUGH PROJECTS THAT TARGET REAL-WORLD CHALLENGES, SUCH AS ENERGY-EFFICIENT HOME DESIGN AND QUALITY CONSTRUCTION.

How did Virginia Tech's FutureHAUS rise from the ashes to climb to the pinnacle of design for the world's solar homes?

The task wasn't easy, but the team succeeded by building on the very foundation of the university's vision for the future, Beyond Boundaries. The project unites students and faculty from various colleges and disciplines in building a net-zero energy home incorporating new methods of prefabrication, technology, and sustainability.

"We have the most interdisciplinary team that we've ever had around any research project, and that's what it takes. That's the secret," said Joe Wheeler, architecture professor and lead faculty of FutureHAUS Dubai.

In November 2018, the FutureHAUS Dubai team earned first place in the 2018 Solar Decathlon Middle East, a competition to accelerate research on building sustainable, grid-connected solar homes launched by the U.S. Department of Energy and the United Arab Emirates' Dubai Electricity & Water Authority. The lone American entry, the Hokie-built, 900-square-foot home outranked 14 teams selected from a pool of 60 entrants.

The win is the culmination of nearly two decades of research, two years of accelerated development after the previous iteration was destroyed in a 2017 fire, and more than a month spent in a desert near Dubai erecting the structure.

In addition to achieving first place overall, the FutureHAUS Dubai team earned first



WE HAVE ALWAYS BELIEVED IN THIS CONCEPT, BUT NOW THE WORLD BELIEVES IN THIS CONCEPT AS WELL. [THE CONCEPTS PROPOSED BY FUTUREHAUS], NOW THAT WE'VE BUILT IT, SEEM VERY REAL, SEEM VERY POSSIBLE, WHICH EXCITES ME THE MOST: THAT MAYBE SOMEDAY, THOUSANDS OF PEOPLE COULD LIVE IN A HOUSE LIKE THIS."

LAURIE BOOTH,
STUDENT TEAM LEAD OF FUTUREHAUS DUBAI



place honors in architecture and creative solutions, second place in energy efficiency and interior design, and third place in sustainability and engineering and construction.

Moving FutureHAUS Dubai from concept to reality was a university-wide effort. Virginia Tech's College of Architecture and Urban Studies, College of Engineering, Myers-Lawson School of Construction, Pamplin College of Business, College of Liberal Arts and Human Sciences, and the College of Science, as well as various centers and labs across campus, contributed to the success of the project.

"I have never experienced this much interdisciplinary knowledge going back and forth every single day to get something done," said Michelle Le '18, who was a student architectural design leader for the team.

The FutureHAUS Dubai team was tasked with creating a home that serves the needs of an aging population, addresses growing environmental concerns, and integrates secure smart systems for an increasingly connected but security-concerned population.

The house was equipped with 67 devices, including touch screen control panels, automatic sliding doors, a smart mirror to help users find their clothes, and a moveable wall to adjust floor plans using what the team calls "flex space."

The cutting-edge innovations extended to the home's garden, but rather than implementing even more technology, the team leaned on its landscape architecture students for a different approach. To adhere to the competition's strict water usage regulations, students incorporated native plants, including four 35-year-old olive trees, that could withstand the intensity of the desert heat.

The current rendition of FutureHAUS grew from the successes of a previous generation of structures. The first FutureHAUS, unveiled room by room over five years in international trade shows, burned in a fire at the Environmental Systems Laboratory at the Prices Fork Research Complex in February 2017. One of FutureHAUS' predecessors, LumenHAUS, won the

international Solar Decathlon Competition in Madrid, Spain, in 2010 and is currently on display behind Cowgill Hall (see related story on page 58). For FutureHAUS Dubai, researchers merged the best features of both.

The team's victory in Dubai not only validates their vision for the home of the future, but also their vision for a new way to tackle the housing needs of an increasingly crowded world with finite resources.

"We have always believed in this concept, but now the world believes in this concept as well," said Laurie Booth, a fourth-year architecture student and a student team lead of FutureHAUS Dubai. "[The concepts proposed by FutureHAUS], now that we've built it, seem very real, seem very possible, which excites me the most: that maybe someday, thousands of people could live in a house like this."

Traditionally, building a home requires an on-site construction process, which is subject to uncontrollable factors, such as weather. FutureHAUS, however, was built entirely in a lab as separate but compatible "cartridges" that are equipped with the walls, floors, ceiling, wiring, plumbing, and finishes.

The all-in-one customizable cartridges can be shipped to a location and easily assembled with a plug-and-play approach.

"Our vision for this house will eventually be to create it on a mass production scale. Just like Henry Ford came and revolutionized the automobile industry by creating assembly lines and mass production techniques, we're hoping that something similar can happen with this house," said Rachel Carie '18, an industrial and systems engineering graduate.

The efficiency of this modular, prefabricated building process paid off for the team during the Solar Decathlon. Virginia Tech was the first team to erect their structure, the first to connect their home to the communications networks, and the first to connect to the power grid on site. The team was one of seven teams awarded bonus points for completing all required inspections by the end of the two-week construction period.

If implemented, the cartridge method could also reap dividends for the homebuilding industry. Homes could be built in mass quantities for lower costs and with greater energy efficiency. Tradespeople like inspectors, electricians, and plumbers could work at a single location, converging disciplines constantly throughout the homebuilding process and yielding a better product.

That drive for innovation has led several companies, including such top sponsors as Dupont, Dominion Energy, and Kohler, to partner with Virginia Tech's team, using the house as a test bed for future projects.

"The house reflects a tremendous amount of thought and work, all kinds of details and all kinds of innovations," said David Christian '76, former executive vice president and chief innovation officer of Dominion Energy and also a mechanical engineering alumnus who spent the last week of the competition with the team in Dubai.

Such involvement has cultivated relationships that are beneficial to industry partners and Virginia Tech.

Although the competition took place more than 7,000 miles away, Alumna Katherine Lelia Hall has learned that no matter how far from Blacksburg she travels, she's never far from a fellow Hokie.

That sense of global community was reaffirmed at the first Hokies in the Middle East alumni networking event in Dubai. An initiative of the Language and Culture Institute, with support from Alumni Relations and the College of Architecture and Urban Studies, the event brought together more than 85 alumni, students, and supporters.

In addition to connecting with fellow Hokies, alumni got an inside look at FutureHAUS. "We were as proud of the FutureHAUS team as if we ourselves were beside them as they developed the house," said Hall, who earned a master's degree in English in 1998 and a doctorate in curriculum and instruction in 2001 and now teaches at Khalifa University in Abu Dhabi.

With the competition behind them, the team has high hopes for what lies ahead. They've already begun researching methods to scale up production, and a new team of industrial and systems engineering students is exploring a facility concept for manufacturing the houses.

For the immediate future though, members say they're happy to spend a little time reflecting on what they were able to accomplish together. ■



“SERVING ON THE BOARD OF VISITORS GAVE ME HUGE INSIGHT INTO VIRGINIA TECH AND WHAT IT CAN DO NOT ONLY FOR THE REGION, BUT FOR THE STATE AND FOR THE WORLD. THERE ARE SO MANY THINGS THAT ARE IMPRESSIVE ABOUT VIRGINIA TECH, BUT MOST IMPRESSIVE OF ALL ARE THE STUDENTS. THERE IS JUST A SENSE OF DEDICATION AT VIRGINIA TECH THAT’S UNLIKE ANY UNIVERSITY I’VE EVER SEEN. YOU KNOW, THE MOTTO OF *UT PROSIM* IS SOMETHING THAT IS INSTILLED IN EVERY STUDENT AT VIRGINIA TECH. EVERY GRADUATE IS RIGHTFULLY PROUD OF VIRGINIA TECH—THEY DON’T KEEP IT A SECRET. THEIR ENTHUSIASM IS CONTAGIOUS AND JUST A WONDERFUL THING TO HAVE.”

Heywood Fralin

HOKIE

AT HEART

STORY BY MASON ADAMS
ART BY JONNY RUZZO

Heywood Fralin wanted to do something different. His older brothers had enrolled at Virginia Tech, so the younger Fralin chose the University of Virginia, a decision that would fuel sibling and sports rivalries for many years.

Hokie culture, however, was woven deep into Fralin's family life, so when Virginia Tech first asked him to serve in early 1993, he did not hesitate.

Older brother Horace Fralin '48, a longtime Hokie and successful leader in education and philanthropy, had died recently from cancer. A new member of the Virginia Tech Board of Visitors, Horace Fralin had attended only one meeting prior to his death.

Then-Virginia Tech President James D. McComas reached out to the younger brother, Heywood Fralin, with an unusual request.

"Jim called me, and he said 'I have a crazy question for you,'" Fralin remembered, 25 years later. "He asked me if the governor were willing to appoint me to the Virginia Tech Board of Visitors for Horace's unexpired term, would I be willing to serve? I said, 'Jim, if you're crazy enough to ask, I'm crazy enough to serve.'"

That step was just the first in the Wahoo's relationship with the Hokie Nation—a journey that culminated on a frigid day in December 2018, as dozens of western Virginia leaders gathered to celebrate the largest philanthropic gift in Virginia Tech history.

Heywood Fralin and his wife, Cynthia, in concert with the Horace G. Fralin Charitable Trust, have committed \$50 million to support biomedical research at the newly named Fralin Biomedical Research Institute at VTC. The institute is an integral part of the growing Virginia Tech Carilion Academic Health Center based at the Virginia Tech Carilion Health Sciences and Technology Campus in Roanoke.

"This transformative gift raises the bar on what we can accomplish in biomedical research," said Virginia Tech President Tim Sands. "We are incredibly grateful, and we look forward to drawing on this tremendous support in order to make powerful discoveries that will improve lives."

"Thanks to Heywood Fralin and his family, we're much better positioned to recruit additional world-leading researchers to address biomedical problems of global scope," said Michael J. Friedlander, the executive director of the research institute and the vice president for health sciences and technology at Virginia Tech.

The record-breaking commitment of support is in keeping with Fralin's lifetime legacy of service—to Virginia Tech, to his alma mater the University of Virginia, to the Roanoke Valley, to Virginia, and beyond.

Fralin is a Roanoke-born attorney, businessman, health care executive, and patron of the arts. He has served as a member of the Board of Visitors, not only for Virginia Tech, but also for the University of Virginia, and his advocacy and leadership have provided critical momentum for giant strides in bringing the Roanoke and New River valleys together.

Ask him for his title, though, and it's clear which role comes first: "Husband."

That answer speaks not just to his devotion to his wife, but to his family and to the Roanoke community, where he was born and grew up as the youngest of three brothers. His parents, Grover Gordon Fralin and Ollie Elizabeth Fralin, moved to the city from rural Franklin County in the 1920s.

"My father only had a seventh-grade education, but he was an entrepreneur and was very interested in providing for his family," Fralin said. "He worked hard every day and began a building construction business. Meanwhile, our mother was very interested in her children, and thought the best way to promote our futures was to make sure that we were well-educated."

Fralin's firm work ethic became evident in the 1950s, when he landed his first job as a paperboy at age 13.

His older brothers enrolled at Virginia Tech to pursue undergraduate degrees, eventually going on to enjoy successful careers. Wayne Fralin became a medical doctor, while Horace Fralin built a life around construction, health care, education, and philanthropy. (The Fralin Life Science Institute at Virginia Tech was named to honor Horace Fralin and his wife, Ann, and in 1992, he received the university's Ruffner Medal in recognition of notable and distinguished service to the university.)

Despite his brothers' successes, Heywood Fralin chose a different path, attending the University of Virginia, where he earned a bachelor's degree. He continued his education at American University, earning a law degree and then going to work as a practicing attorney before entering the business world in 1993.

Fralin never drifted far from Virginia Tech, though, remaining connected to the university through his family's history, further fueled by brotherly feuding over sports. And when President McComas asked him to serve out his late brother's term on the Board of Visitors, Fralin's commitment to service demonstrated that he's a Hokie at heart, if not in experience. Those seven years on the Board of Visitors have informed his work ever since.

Fralin leveraged the experience when he later served on the University of Virginia Board of Visitors.

"I kidded them by telling them that everything that I learned about board governance, I learned on the Virginia Tech Board of Visitors," Fralin said. "It was not always well received by some of my UVA colleagues, but it was a fun thing to say."

"UVA benefited tremendously from Heywood Fralin's time on the Virginia Tech Board of Visitors," said John Casteen, former UVA president. "We've seen firsthand the effects of his energy and commitment to a vision. And his work with Virginia Tech is a great thing not just for Roanoke, but for Virginia as a whole."

Fralin is chairman of the State Council of Higher Education for Virginia, commonly known as SCHEV. He has chaired the Virginia Business Council and the Virginia Business Higher Education Council. He served as a member of the advisory board of Carter Immunology Center at the University of Virginia and on the Council on Virginia's Future. He also served as a member of the Governor's Commission on Higher Education Reform, Innovation, and Investment. He currently serves on the GO Virginia Board and the Virginia Research Investment Committee.

Fralin and his wife have agreed to bequeath their collection of works by American artists to the University of Virginia, which resulted in the naming of the Fralin Art Museum on its campus. He also serves as vice chair of Roanoke's Taubman Museum of Art.

Heywood Fralin has become a central figure in the Roanoke Valley and one of its most outspoken advocates.

"I consider Heywood Fralin a true, longtime leader in our community," said Roanoke Mayor Sherman Lea. "He's not a person who gets a lot of headlines, but he's intricately involved in the community, and it shows."



Fralin's vision for regional cooperation and investment in growing industries has undergirded Roanoke's economic transformation from a blue-collar railroad hub into a forward-looking, tech-savvy, outdoors mountain city.

"I grew up in Roanoke when Norfolk Southern was everything," Fralin said. "The idea that Norfolk Southern would ever leave Roanoke was unheard of. We all believed that Norfolk Southern would be here forever. But, as we all know, this economy has moved from an energy-based economy to a knowledge-based economy."

"Today, we are very reliant on two things: small start-up businesses, which I believe are going to be the future of the entire nation, and the health care enterprises that are being created in our area through Virginia Tech and Carilion. The evolution of the VTC School of Medicine and the research institute and the emergence of a VTC Academic Health Center to help discoveries come to market and be applied are going to be the future of our region," he said.

Now, through his generous financial commitment, Heywood Fralin is making a significant investment into his vision. The contribution builds on his personal and family history of service and philanthropy, which reaches across the state, touching on research, education, the arts, and economic development.

"I tend to think in terms not only of Roanoke, but Roanoke's involvement in the entire state," Fralin said. "I have chosen to be involved in both the state and in the locality. I just believe that it's the responsibility of everyone to give back to their community and state and to leave things better than they found them." ■

"THE EVOLUTION OF THE VTC SCHOOL OF MEDICINE AND THE RESEARCH INSTITUTE AND THE EMERGENCE OF A VTC ACADEMIC HEALTH CENTER TO HELP DISCOVERIES COME TO MARKET AND BE APPLIED ARE GOING TO BE THE FUTURE OF OUR REGION,"

Heywood Fralin

WELCOME TO
ALEXANDRIA

With the addition of the Virginia Tech Innovation Campus, the nation's greatest talent will call National Landing home. We are building a historic partnership to change the future, together.

ALX + VT

Innovation lives here.



For more information on Alexandria, visit:

GROWALX.COM

It's not too late to
secure your 2019-2020
housing needs!

**Student/Professional
Rentals AVAILABLE!**



Reputable • Reliable • Recommended

www.PointeWestMangement.com

**Also Offering Full
Brokerage Services**

LEAD ON.

Your university calls. Your legacy continues.

Empower others to learn at Virginia Tech, serve their communities, and make a difference in the world.

Maximize tax benefits and your philanthropic impact.

Contact us to learn more.

givingto.vt.edu/giftplanning

giftplanning@vt.edu

540-231-2813





AROUND THE HOKIE NATION

- 45 Class Notes
- 54 Travel Profile
- 58 Retro
- 63 Alumni Commentary
- 64 Family

COMING HOME

JUSTIN GRAVES KEEPS THE UT PROSIM PYLON CLOSE TO HIS HEART, LITERALLY.

During a recent visit to campus, Graves '12, MAED '14 had the pylon's exact geographic coordinates tattooed on his left side of his chest, just over his heart.

For Graves, the pylon bearing the university's motto, *Ut Prosim* (That I May Serve), is an all-inclusive connection to his family's military history, his personal drive to serve, and his experience finding his lifelong home in Blacksburg.

"Being a person of color, being a person with a disability, you know, at Tech I found so many different pockets of friends and so many people that were accepting of the person I was. My life growing up was not always that way. I was like, 'Wow, this is a place that truly feels like home,'" Graves said.

Graves, who was diagnosed with a rare spinal inflammation as a child, credits his parents, Margo and Larry Graves, with helping him develop a spirit of persistence and positivity.

"They always were focused on not treating me any different than my other siblings," Graves said. "That's definitely a mindset I've carried with me throughout my life."

During his time at Tech, Graves served as a Hokie Ambassador, which involved giving campus tours. He also worked at the Collegiate Times, a position that enabled him to interview top-level administrators as a news reporter and then as the public editor.

Justin Graves



“ I WAS ALWAYS THINKING ... HOPEFULLY AN INTERACTION WITH ME, OR JUST SEEING ME, COULD CHANGE THEIR PERSPECTIVE AND HELP THEM SEE THAT **BLACKSBURG IS A COMMUNITY WHERE ANYONE CAN THRIVE.**”

Justin Graves '12, MAED '14

Today, Graves lives in Northern Virginia, where he works as a project manager for the Department of Homeland Security. To encourage others he founded HES-ONWHEELS, promoting himself as a motivational speaker and blogger.

Although he now lives a few hundred miles away, staying active in the Virginia Tech and Blacksburg communities is important to Graves. He's served on a number of boards, including the Multicultural Alumni Advisory Board and the YMCA at Virginia Tech Board of Directors, and he is currently a member of the Virginia Tech Alumni Association's Board of Directors.

Graves' passion for Virginia Tech has become somewhat legendary, but he admits that wasn't always the case. In fact, he became a Hokie in part by accident.

While applying for early admission, he failed to read the fine print, so once accepted, his parents had to clear up his misunderstanding about Virginia Tech merely being an option.

“My parents clarified and explained, ‘No, if you got in here, you have to go.’ They were right,” Graves said. “But I wouldn't change it for the world.”

A chance encounter at an ice cream social led Graves to pursue one of the roles for which he would become well-known on campus. There, Courtney Smith introduced him to the Hokie Ambassador program and addressed Graves' concern that he may not be able to give a quality tour from his wheelchair.

“Having met me 10 minutes prior, she was like, ‘You really don't seem like the type of person that would let that hold you back,’ and I thought about it, and I was like, ‘Damn, she's right,’” Graves said.

Graves would go on to lead campus tours throughout his time as an undergraduate

and as a graduate student. In one semester, he led 35 tours.

Graves said he hoped to demonstrate the opportunities underrepresented populations have at Virginia Tech to those who might believe otherwise.

“I was always thinking ... hopefully an interaction with me, or just seeing me, could change their perspective and help them see that Blacksburg is a community where anyone can thrive,” Graves said.

A highlight of his senior year, Graves was selected to representing the college newspaper on the Homecoming Court. To generate support across campus, Graves' friend Jamie Chung suggested the slogan, “Justin Graves: He's on wheels.”

Although Graves finished as the runner-up, the motto has evolved into a personal brand to promote his work as a motivational speaker and to help him advance his goal of meeting one new person each day.

This year, there have been three days during which he hasn't met a new person, which pushed his total of days missed since 2008 to about a dozen.

An extrovert to his core, Graves aims to inspire others to step out of their comfort zones and hopes that the effort might result in a world that more closely resembles the community he experienced during college. ■ TW



DM, LOGAN WALLACE

CLASS NOTES

Alumni, we want to hear what you've been doing. Mail career, wedding, birth, and death news to Class Notes, Virginia Tech Alumni Association, Holtzman Alumni Center, 901 Prices Fork Rd., Blacksburg, VA 24061; email the information to classnotes@vt.edu; or submit the news online at vtmag.vt.edu/submit-classnote.php, where photos may also be uploaded for consideration.

For assistance, call 540-231-6285.

'57

CAREER James Wesley Garner Jr., Roanoke, Va., is the namesake of the Virginia Department of Forestry headquarters building in Charlottesville, which was dedicated in April 2018.

'60

CAREER Richard Thomas Crowder, Alexandria, Va., was reappointed C.G. Thornhill Professor of Agricultural Trade at Virginia Tech.

'62

CAREER William Carpenter Emerson, Rochester, N.Y., co-edited “Don't Tell Father I Have Been Shot At,” a book of Civil War letters written by his great-grandfather.

Winfred Marshall Phillips, Gainesville, Fla., was presented with the Albert Nelson Marquis Lifetime Achievement Award by Marquis Who's Who as a leader in engineering.

'64

CAREER William Nalley Barker, Oro Valley, Ariz., earned the 2018 Air Force Space and Missile Pioneers Award and was inducted into the Air Force Space and Missile Hall of Fame.

'67

CAREER Leigh Morton Vaughan, Cary, N.C., received a Certificate of Appreciation from the Research Triangle Chapter of American Association of Individual Investors for service as program chair from 2016 through 2018.

'68

CAREER Robert Clifton Morecook, Sugar Land, Texas, completed 12 years in the Texas State Guard as a unit commander and public affairs officer.

'69

CAREER William Randolph Simpson, Edgewater, Md., received the 2017 Best Paper Award from the International Conference on Computer Science and Applications.

'70

CAREER Carl Grayson Roe, Carlisle, Pa., was elected to the Wildlife for Everyone Foundation board of directors.

'72

CAREER Thomas Joseph Fagan, Kissimmee, Fla., is chair of the National Commission on Correctional Health Care board of directors.

'74

CAREER Patricia Elaine Brown, Palmyra, Va., received the Mark Herring Award from the 10th Congressional District Democratic Committee.

J. Michael Solomon, Greensboro, N.C., received the Order of the Long Leaf Pine from North Carolina Gov. Roy Cooper, recognizing 40 years of community service.

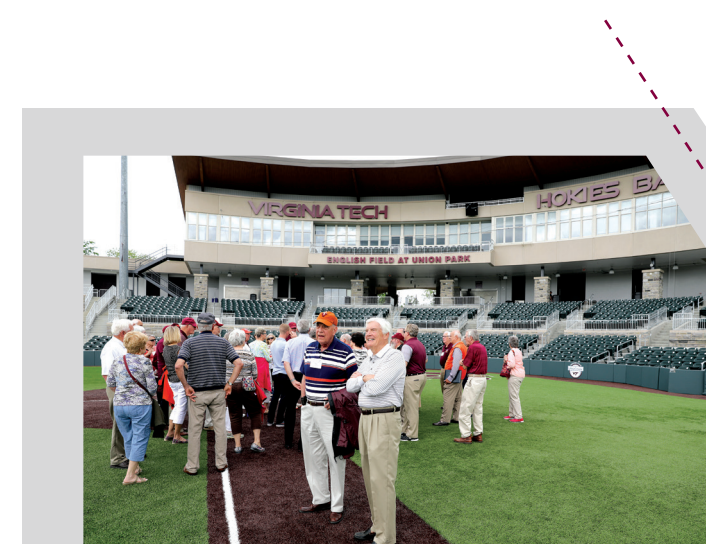

A TIMELESS TRADITION

Members of Virginia Tech's Old Guard Society of Golden Alumni are among the university's most respected and revered Hokies. The group was established in 1967, and each fall, alumni of the class who graduated 50 years earlier are inducted into the Old Guard.

In the spring, new and returning Old Guard members visit campus for their reunion. This year they will gather May 22-24 and welcome the newest members of the group: the Class of 1968.

During the 2019 reunion, Old Guard members will be invited to tour campus, gather for class dinners, learn about campus developments in Blacksburg, Roanoke, and Northern Virginia, and hear an update on Virginia Tech athletics.

Learn more: alumni.vt.edu/oldguard

SIXTY AT SIXTY

LAST FALL, WILL TURNER '80 RAN through Blacksburg on his way toward setting a Guinness World Record.

"In retrospect, it was really important because it was so fun to be here in Blacksburg and on campus," said Turner the morning after he completed his New River Valley-based Ironman. "It just brings back a flow of good memories, and just the energy you see on campus with the students, it's just fun to be here."

The race was the 49th out of 61 Ironman races Turner completed during his 60th year of life—he turned 61 on Jan. 7—breaking the previous world record of 44 completed races in a year.

"I do this because it's hard," Turner said. "It pushes me, and it challenges me because you're always having to battle yourself and push through whatever obstacles you've got."

Turner, who completed his first marathon in 2009, said the idea for the year of endurance started about

three-and-a-half years ago.

"I originally thought I would do six [Ironman races] when I turned 60, but someone mentioned someone else who had done that, and it kind of deflated my bubble a little bit," he said. "I started mulling it over in my head and for some reason, decided 60 at 60 has a nice ring to it."

The goal has taken Turner across the country and back more than once, and while he said his body has held up surprisingly well, each race comes with its own unique test of his physical and mental will.

"You get to that point of inflection where you just want to stop and every cell in your body is wanting to slow down ... and you have a choice, either stop, slow down, or push through it," Turner said. "I call that the sweet spot. In the moment it's not sweet at all. In the moment you're full of pain, but afterwards, if you push through it, you learn a lot about yourself." ■ TW

61
Number of races

5
Pairs of running shoes

11,000
calories burned per race

8,576.6
Combined miles of all races

140.6
Total distance of each race (2.4 miles swimming, 112 miles cycling, and 26.2 miles running)

92°F
Hottest weather competed (Oregon) with radiant heat of about 106°F

38°F
Coldest weather competed (Virginia)

8
bike tires

SETTING THE PACE: Will Thompson runs past Burruss Hall, (left) bicycles along Catawba Rd., and races near the Duck Pond during an event in Blacksburg, Virginia.

“

I DO THIS BECAUSE IT'S HARD, IT PUSHES ME, AND IT CHALLENGES ME BECAUSE YOU'RE ALWAYS HAVING TO BATTLE YOURSELF AND PUSH THROUGH WHATEVER OBSTACLES YOU'VE GOT."

Will Turner '80



BY THE NUMBERS

See more statistics related to Will Turner at vtmag.vt.edu.

— '75 —

CAREER Sidney Christopher Curtis, Powhatan, Va., received the Leadership in Alcohol Regulation Award.

Lewis Lee Lanier, San Francisco, Calif., was named to the Dragonfly Therapeutics Scientific Advisory Board.

— '76 —

CAREER Joseph Harold Maroon, Midlothian, Va., was inducted into the National Association of Conservation District's Southeast Region Hall of Fame.

Samuel Minor Redd, Bloomington, Ill., retired from State Farm Insurance after 32 years as a systems analyst.

— '77 —

CAREER Charles Graham Burress Jr., Blacksburg, Va., retired after 41 years with Landmark Media Enterprises.

Robert Warren Russell, Millville, N.J., is instructional chair of Salem Community College's scientific glass technology program.

Patricia S. Sims, Reston, Va., is the director of the Office of Mediation Services. She is the first woman to hold the position.

— '78 —

CAREER Donna Lynn Rowley Bolls, Charlotte, N.C., earned certification as a therapy dog team, along with golden retriever Holly.

Hank Allen Leddon, Springfield, Va., retired from the Federal Reserve Board on Sept. 1, 2018, after 36 years of service.

Mitchell Linda Sue Motley, Floyd, Va., retired after 28 years in ministry.

Dennis Henry Treacy, Hanover, Va., has joined Reed Smith LLP as senior counsel in the government relations and administrative law group.

— '79 —

CAREER Rouse Roby Bailey Jr., Parkton, Md., retired as vice president of Power Tool Technologies, Stanley Black & Decker, after a career spanning 39 years.

Deborah Lynn Fitzgerald Custer, Blue Ridge, Va., is a licensed grower of hemp and licensed processor of hemp-derived products.

Frederick Xavier Turck, Stanardsville, Va., earned a fourth Smokey Bear Award for fire prevention initiatives.

— '80 —

CAREER Howard John Schellenberg, Plantation, Fla., purchased the rights to Stephen King's short story "Beachworld," for one dollar.

— '81 —

CAREER Margaret Halpin Dohnalek, Randolph, N.J., joined Valensa International as chief scientific officer.

Thomas James Straka, Pendleton, S.C., was named the Forest Landowners Association's 2017 Extension Forester of the Year and received the Society of American Foresters 2017 John A. Beale Memorial Award.

— '82 —

CAREER George M. Hopper, Starkville, Miss., received the 2017 Southern Association of Agricultural Experiment Station Directors ESS Excellence in Leadership Award and was named Alumnus of the Year by Hinds Community College.

— '83 —

CAREER Darren Reynolds Conner, Callands, Va., was promoted to president of Dewberry Engineers Inc.

Paige E. Hausburg, Richmond, Va., who retired from public service after 35 years, was recognized for her work with tribal communities by the National Association of Tribal Child Support Enforcement.

Jay Braddock Jackson, Fredericksburg, Va., retired after 34 years with Geico Insurance Co. and established the Law Offices of Jay B. Jackson PLLC, specializing in elder law, estate planning, and personal injury.

Ray Matthew Kaplan, Athens, Ga., received the Distinguished Veterinary Parasitologist Award from the American Association of Veterinary Parasitologists.

— '84 —

CAREER Kendley J. Davenport, Leesburg, Va., joined Springboard Education in America as chief development officer.

Peter Rudolf Engel, White Post, Va., is eastern regional sales manager for CEMB-USA, a leading manufacturer of wheel service equipment.



SAVE THE DATES

Hokies in L.A.
March 19

Virginia Tech Denim Day 40th Anniversary Commemoration
April 2-6

Old Guard Society of Golden Alumni Reunion
May 22-24



Reunion Weekend 2019
June 6-9



Beer Festival at Virginia Tech
June 22

Women in Business
Sept. 19

For more information, including a complete listing of events, visit alumni.vt.edu/events.

Benjamin Zion Stallings Jr., Silver Spring, Md., was installed as the 171st president of MedChi, the Maryland State Medical Society.

— '85 —

CAREER Jeffrey Nickson Johnson, Alexandria, Va., won an Ippy Award for Best Regional Fiction for "Other Fine Gifts," a short story collection.

— '86 —

CAREER Jean Neff Guthrie, Smyrna, Ga., released the second novel in her Mystic Aria series on Oct. 17, 2018.

Charles James Otto, Princess Anne, Md., was elected to a third term as delegate in Maryland's House District 38A.

Bettina Kay Ring, Charlottesville, Va., who was selected by Gov. Ralph Northam to serve as secretary of agriculture and forestry, was elected a Fellow and received the Sir William Schlick Award from the Society of American Foresters.

— '87 —

CAREER Daniel Frederick Mahony Jr., Rock Hill, S.C., received the Academic Achievement in Sport and Entertainment Award from Sport Entertainment and Venues Tomorrow.

— '88 —

CAREER Mark Thomas Scott, Beckley, W. Va., is assistant chief of Fisheries Management for the West Virginia Division of Natural Resources.

Mark Steven Tisa, Princeton, Mass., has been appointed director of the Massachusetts Division of Fisheries and Wildlife.

— '89 —

CAREER Peter David Breil, Richmond, Va., was appointed by Richmond Mayor Levar Stoney as the city's first director of the Department of Citizen Service and Response.

Rodney Perry Gaines, Norfolk, Va., was named 2018 College Physical Educator of the Year by the Virginia Association of Health, Physical Education, Recreation, and Dance.

John Eugene McDonald Jr., Worthington, Mass., received a 2018 Outstanding Alumni Award from Penn State's Forest Resources Alumni Group.

— '90 —

CAREER Constantine John Peroulas, Charlotte, N.C., was named Showmars CEO.

— '91 —

CAREER Stephen Carl Laycock, Burke, Va., was named assistant director for the Directorate of Intelligence at FBI headquarters.

Nandita Rastogi Mishra, Bloomfield Hills, Mich., was promoted to senior associate for TMP Architecture Inc. and received the Accredited Learning Environments' planner designation.

Marion Mason, Los Fresnos, Texas, is the new public affairs specialist for the Hoosier National Forest.

Larry Paul Thompson, Jupiter, Fla., was named CEO at Veriato.

— '92 —

CAREER Teresa A. Martinez, Pine, Colo., received Virginia Tech's Gerald H. Cross Alumni Leadership Award.

Greg Alan Scheerer, Lynchburg, Va., received the Distinguished Service to Forestry Award from the Appalachian Society of American Foresters.

Grant Eric Walker, Christiansburg, Va., is corporate director of national accounts for ECS Mid-Atlantic LLC.

— '93 —

CAREER Karen Bleattler Schommer, Blaine, Minn., was appointed district court judge in Minnesota's 10th Judicial District.

— '94 —

CAREER Carl Justin D'Silva, Chicago, Ill., is managing principal with Perkins+Will.

James Scott Lowman, Altavista, Va., was named director of applied research for the Institute for Advanced Learning and Research.

Cynthia Anne Whitbred-Spanouilis, Virginia Beach, Va., has appointed director of the Department of Aquarium, Historic Houses, and Museums, and executive director of the Virginia Aquarium Foundation.

— '95 —

CAREER Gregory Ivan Abel, Pawtucket, R.I., is director of marketing and communications at The Providence Country Day School.

Anne Elizabeth Pond Gerlach, Saint Charles, Ill., published "Ben's Adventures," a children's book whose proceeds support the Ben Smiles Memorial Foundation.

Michelle Jacqueline Krusiec, Los Angeles, Calif., made her Off-Broadway debut in the Public Theater's "Wild Goose Dreams."

Stefanie Felice Lazanov Wood, Vienna, Va., is director of business travel for Kalibri Labs.

— '96 —

CAREER Timothy Burdick, Bedford, N.H., was named director of outdoor programs at Dartmouth College.

John Euler Whitley, Alexandria, Va., was confirmed by the U.S. Senate as assistant secretary of the Army (financial management and comptroller).

Robert Bryan Wyks, Leesburg, Va., retired as lieutenant colonel from the U.S. Army Reserves.

— '97 —

CAREER Ashley Stewart Owens, Roswell, Ga., authored "At the Corner of Main and Crazy," a novel.

Kevin Anthony Pennock, Richmond, Va., is an associate and senior project manager in the land planning and development department at Dewberry.



BUILDING EQUITY

Robbie Werth's professional career is all about equalizing opportunity.

As the founder of Diamond Transportation Services Inc., now a subsidiary of National Express Transit, Werth '74, MBA '81 works with local and regional transit agencies in the D.C. metropolitan area to design, implement, and operate paratransit services for persons with disabilities. His innovative work and advocacy have garnered numerous awards and made him a sought-after expert.

Werth has expanded on his interest in accessibility and equal rights for people with disabilities with a generous gift to Virginia Tech's Services for Students with Disabilities.

Learn more about how Werth is making a difference for Virginia Tech students at vtmag.vt.edu.

CORPORATE CONNECTIONS

A NEW CHAPTER FOR ALUMNI



A GROUP OF HOKIES IN MCLEAN, Virginia, has helped Virginia Tech record an important first—the university’s inaugural corporate alumni chapter.

Launched just two years ago with a modest kickoff and 75 members, the Freddie Mac Chapter of the Virginia Tech Alumni Association has grown to 200 members.

“We’re still trying to find everyone,” said Russell McDiffett ’06, a chapter co-chair who works in investments and capital markets at the company.

Traditional alumni chapters are organized based on geography. Alums in a region organize to socialize and serve their local communities. A chapter based not on region, but in a company, is an idea that works especially well in Northern Virginia (Freddie Mac in particular), where people are commuting from different areas.

Marvin Boyd ’00, who works in information technology at Freddie Mac and had served previously as president of the National Capital Region Chapter, said the corporate chapter structure makes it easier for Hokies to connect.

“Hokies are spread across multiple buildings,” he said. “Our chapter creates a stronger, more welcoming community for a diverse organization for all employees.”

McDiffett said the chapter’s outreach has grown along with its numbers. The group has planned a session to provide

guidance on the college admissions process, held a corporate-wide volleyball tournament and a Habitat for Humanity build, and participated in take-your-child-to-work day.

The chapter’s most recent event, a panel discussion on leadership featuring Freddie Mac executives who are also Virginia Tech alumni, was held in November, drew 100 participants, and was livestreamed to dozens more across Freddie Mac’s regional offices.

The event took place just hours before the university officially announced transformative news: the creation of the Virginia Tech Innovation Campus and with it a \$1 billion investment. According to Boyd, the announcement sparked a buzz of energy and curiosity.

“Hokies (and non-Hokies) were proud that Virginia Tech played such a major role in bringing Amazon to Virginia,” Boyd said.

With a successful partnership between Virginia Tech and Freddie Mac, Boyd and his colleagues are looking for ways to build on their success. Boyd would like see other corporate chapters formed and hopes that will lead to further relationships between the companies.

Even though the Freddie Mac Chapter is the first, it won’t be the last. ■

Annie McCallum is the director of communications for alumni relations.



LINKED IN: The Freddie Mac Chapter of the Virginia Tech Alumni Association sponsors networking and social events that bring together Hokie alumni.

’98

CAREER James William Barnes, Buford, Ga., earned an MBA from North Carolina State University and was hired as director of enterprise architecture for IT solutions with Pimerica.

Diana F Karczmarczyk, Alexandria, Va., co-authored a children’s book, “It’s GREAT to be YOU!”

Christopher George Knehr, Midway, Ky., joined the sales team at WinStar Farm.

Mark Andrew Lowry, Arlington, Va., is president and chief revenue officer of Association Analytics.

’99

CAREER Kevin Baird, Middletown, Del., was named a 2018 Top Lawyer by Delaware Today.

Steven K. Kuntz, Haymarket, Va., is transportation business unit manager of Dewberry’s Fairfax office.

Deborah L. Eareckson Siachos, Oxford, Md., is supervisor of human resources for Caroline County Public Schools.

WEDDING James Samuel DeGenova and Stacey Lynn Knight ’04, Washington, D.C., 8/11/18.

’00

CAREER Marshall Ray Eichfeld, Midlothian, Va., joined Draper Aden Associates as a senior project manager with the Site Development and Infrastructure Team.

BIRTH Jessica M Bryant and Wesley Allen Gwaltney ’03, Newport, Va., a daughter, 8/1/18.

’01

CAREER Jeremy Michael Barbour, Salem, Va., is founding principal of Tacklebox Architecture, a firm which has received numerous awards and been cited in many publications. Barbour was named to Architect’s Newspaper’s Top 50 Interior Architecture Firms.

Peter Daniel Hancock, Nashville, N.C., was named Roanoke timberlands manager for Roseburg Forest Products.

Jennifer Saunders Hill, Virginia Beach, Va., was named First Colonial High School’s 2018 Teacher of the Year.

BILL PETROS

CHRISTINA FRANUSICH

BIRTH Stephanie Clevenger Behling, Frederick, Md., a son, 6/12/18.

Erin Coe Fristoe and John Kramer Fristoe, Woodbridge, Va., a daughter, 2/27/18.

Daniel Raymond Longo and Kristin Longo ’05, Easton, Pa., a son, 11/24/18.

’02

CAREER Nicholas James “Coop” Cooper, Midlothian, Va., is vice president and lead architectural designer at HKS Architects.

Stephanie Gerke George, Greenville, N.C., is a tenured associate professor in the Department of Engineering at East Carolina University with research interests in cardiovascular imaging and modeling, medical device design, and active learning in engineering education. The principle investigator of an NSF-funded Research Experience for Undergraduates, George was selected to participate in the Bridges Leadership Training program.

BIRTH Sharnnia Artis Trimble, Irvine, Calif., a daughter, 2/7/18.

’03

CAREER Sarah Lynn Smidl, Christiansburg, Va., is interim chair of the Master of Occupational Therapy Program in Radford University’s Waldron College of Health and Human Services.

Stephanie R. Smith, Seattle, Wash., opened Cogwheel Marketing, which is devoted to hotel digital marketing and e-commerce.

BIRTH Wesley Allen Gwaltney and Jessica M Bryant ’00, Newport, Va., a daughter, 8/1/18.

Scott William Hotop, Raleigh, N.C., a daughter, 10/15/18.

’04

WEDDING Katherine Louise Weaks Crumble and Grayson Crumble, Henrico, Va., 8/25/18.

BIRTH Sabrina Mae Chin, Great Falls, Va., a son, 7/6/18.

Jessica Lauren Clem Tabb and John Marshall Tabb, Charleston, S.C., a daughter, 8/25/18.

’05

CAREER Apryl Alycia Alexander, Opelika, Ala., spoke at TEDxMileHigh in Denver, Colo.

Allison Jennifer Ames, Athens, Ga., is on the faculty of the College of Education and Health Professions at the University of Arkansas.

Thomas Michael Cusick, Mebane, N.C., is principal with Blankenship & Keith P.C.

Laura June Morgan Freeman, Alexandria, Va., received the 2017 Andrew J. Goodpaster Award for Excellence in Research from the Institute for Defense Analyses.

David Michael Leonard, Fredericksburg, Va., is vice president for government affairs for the American Sportsfishing Association.

Brigitte Kumbier Orrick, Colorado Springs, Colo., is director of recruiting and employee development for the Davey Tree Expert Co.

Thomas Dudley Schneider, Arlington, Va., founded Rooftop Roots, a nonprofit with a mission to install gardens on rooftops of affordable housing across the Washington, D.C., area.

Shomir Jeffrey Wilson, Cincinnati, Ohio, is an assistant professor in the College of Information Sciences at Pennsylvania State University.



GIVING BACK

Christina Todd ’09 is a vice president and financial advisor at Cary Street Partners in Richmond, Virginia. She has been in the financial services industry for more than eight years.

Todd, pictured above with Robert Sumichrast, dean of the Pamplin College of Business, also serves as president of the Pamplin Recent Alumni Board.

In 2018, Todd received the Virginia Tech Outstanding Recent Alumnus Award, which recognizes leadership, community service, and occupational achievement. In 2017, she received one of the college’s Rising Alumni Awards, created by the Pamplin Society to honor outstanding alumni.

For more about Todd, go to magazine.pamplin.vt.edu/issues/fall-2018/christina-todd-giving-back-to-ensure-student-success.



WELCOME TO THE FAMILY: More than 2,400 Hokies became Virginia Tech alumni in December 2018.

BIRTH Justin Adam Yalung and Jessica A. Yalung '08, Blacksburg, Va., a daughter, 10/18/18.

'06

CAREER Ryan Christopher Bar-noski, Falls Church, Va., is partner at Lanigan, Ryan, Malcolm & Doyle P.C.

Boyd Patrick Harrison, Fairfax, Va., is owner and head brewer of Chubby Squirrel Brewing Co.

Shelby Elaine McDonald, Richmond, Va., was awarded a National Institute of Child Health and Human Development R21 grant.

BIRTH Patricia Ricketts Walker, Alton, Va., a daughter, 3/22/18.

Amanda Mullins Lynch and Stephen Christopher Lynch '09, Midlothian, Va., a daughter, 10/18/18.

'07

CAREER Christian Matthew Bar-low, Manteo, N.C., has been selected as a Fellow with the University of Virginia Medical Center's Department of Hematology/Oncology.

Dustin Daniel Flannery, Philadelphia, Pa., completed a fellowship in perinatal-neonatal medicine at the Children's Hospital of Philadelphia and joined the Division of Neonatology as an attending physician.

BIRTH Jeffrey James Dawley and Katherine Claire Dawley, Ashburn, Va., a son, 6/25/18.

Bryan Richard Orellana and Brooke Shively Clements '09, Fort Wayne, Ind., a son, 10/9/18.

'08

CAREER Elizabeth Renee Breeding, Washington, D.C., joined the National Turkey Federation as vice president of communications and marketing.

Manisha Pravinchandra Patel, Greensboro, N.C., was appointed vice president of the N.C. Association of Women Attorneys, received the 2018 Young Alumna Award from the Elon University Women's Law Association, and was named a Top Lawyer for family law by Business North Carolina.

Elizabeth Jeannette Traut, State College, Pa., is an assistant research professor in the College of Engineering at Pennsylvania State University.

BIRTH Ryan Richard Green and Amanda Hogan Green '09, Hanover, Va., a son, 4/18/18.

Bonnie Elisabeth Hamilton and Quentin Clay Penn Hollar '09, Richmond, Va., a son, 3/26/18.

Melissa Kaitlan Trotman Hollins-head and Mark S. Hollinshead '09, Chesterfield, Va., a daughter, 7/3/18.

Lindsey Elizabeth Ingalls, Manasquan, N.J., a son, 10/28/18.

Stacey Rector Wittelsberger and Raymond Charles Wittelsberger, Baltimore, Md., a daughter, 8/1/18.

'09

CAREER Justin Keith Lucy, Chesterfield, Va., is senior real estate manager for GSA Management.

WEDDING Michael E. Flora and Ashley Anne Flora LeFrois '07, Christiansburg, Va., 5/19/18.

BIRTH Jessica Bjorness Nolen and Brian Matthew Nolen '09, Bethesda, Md., a daughter, 10/3/18.

Kathleen Berger O'Brien and Daniel O'Brien, Saint Louis, Mo., a son, 8/7/2017.

Emilee Crabtree Sinclair, Chesterfield, Va., a daughter, 2/22/18.

'10

CAREER Jeremy Patrick Stovall, Nacogdoches, Texas, received the Arthur Temple College of Forestry

and Agriculture's Teaching Excellence Award from Stephen F. Austin State University.

BIRTH Andrew Gordon Allen and Emily Louise Hindman Allen '11, Pfafftown, N.C., a daughter, 9/1/18.

William Todd Satterwhite and Julie Terrell Satterwhite '11, Vinton, Va., a son, 3/27/18.

Carly Jeannine Temple, Chester, Va., a daughter, 6/28/18.

'11

CAREER Scott William Lyon, Suamico, Wis., was selected as a member of the Wood Industry 40 Under 40 Class of 2018 by the Woodworking Network.

Patrick John Jaffke, Blacksburg, Va., joined the Institute for Defense Analyses as a research staff member in the system evaluation division.

Ashley Nicole Peery, Round Hill, Va., developed materials to train volunteers for the Smithsonian National Museum of Natural History infectious disease exhibit, "Outbreak: Epidemics in a Connected World."

WEDDING John Robert Joyce III and Jessica Rose Maples '12, Haymarket, Va., 4/28/18.

Annah Martchen Latane and Nicholas Charles Zastrow '12, Blacksburg, Va., 8/19/18.

BIRTH Andrew Joseph Hayek, Manasquan, N.J., a daughter, 8/5/18.

Tyler Eric Kercher Williams and Katherine Anne Hall Williams '13, Blacksburg, Va., a daughter, 5/16/18.

'12

CAREER Doray Ann Sitko, Austin, Texas, joined Berry Consultants LLC as senior project manager.

'13

CAREER Daniel Bryce Goff, Wichita, Kan., is product and account support coordinator at AccuWeather Enterprise Solutions.

WEDDING Angela Godwin Tabb and Brian Lewis Lusher '14, Charlotte, N.C., 9/15/18.

'14

CAREER Alexandra Marie Cantwell, Chesapeake, Va., a horticulturist

at Norfolk Botanical Gardens was a 2018 Hampton Roads Business Journal Top 40 Under 40 honoree.

Steven Edwin Mach, Albany, N.Y., joined Barclay Damon LLP as an associate in the torts and products liability defense practice area.

'15

CAREER Kayleigh Elizabeth Burke, Blacksburg, Va., won the 7th Annual ManeJane Alumna Cup at the Intercollegiate Horse Shows Association Alumni Tournament of Champions.

Sarah Michele McKay, Chesterfield, Mo., is director of market development for the National Corn Growers Association.

'16

CAREER Ryan Francis O'Toole, Richmond, Va., who was appointed by Virginia Gov. Ralph Northam as a member of the Board for Professional and Occupational Regulation, also joined the Cozen O'Connor Public Strategies government relations team.

WEDDING Samantha Dawn Metz and David Price, Staunton, Va., 9/29/18.

Tori Janelle Sheets, Blacksburg, Va., and Christopher Vincent, 5/6/2018.

'17

CAREER Taylor James Woodson, Kernersville, N.C., joined CBRE Triad as an assistant real estate manager in the asset services division.

'18

CAREER Peyton David Bright, Blacksburg, Va., joined GuernseyTingle as an architectural designer.

Alec Jeffrey Gilliam, Williamsburg, Va., was reappointed financial representative intern by Northwestern Mutual.

Alexandra Chase Jackson, Charles Town, W.Va., is a systems engineer with Northrop Grumman and serves the West Virginia National Guard as a C17 pilot.

Alexandra J. Shearer, Blacksburg, Va., is a research associate with Lee & Associates Maryland.

GARDENS BRING LIFE TO ANY landscape, gifting sights and smells to communities. Yet that wasn't good enough for Thomas Schneider '05, who uses gardens to grow food and cultivate green-collar job opportunities for underserved communities in Washington, D.C.

Schneider used his experiences in the fish and wildlife conservation program at Virginia Tech to create a business model focused on environmental, economic, and social investment in the D.C. metro area. His nonprofit, Rooftop Roots, uses all facets of the built environment, from commercial rooftops to backyards, to design, install, and maintain edible and conservation landscapes.

In 2011, five years after graduating from Virginia Tech and in the midst of his career as a government contractor with the Environmental Protection Agency,

Schneider had a moment of entrepreneurial enlightenment. He had gathered with friends on top of a D.C. apartment, where they were enjoying a Washington Nationals baseball game just a few buildings away from the stadium. Looking down upon the city, Schneider noticed the office complexes and their barren rooftops. That's when an idea took root.

"I thought, 'Wow, that'd be cool if we could grow some vegetables on there,'" said Schneider. "Then I got this idea—if we could actually grow vegetables for a food bank, maybe an office building would support that."

Schneider founded the nonprofit soon after and began partnering with businesses and homeowners to bring life to barren urban landscapes. Rooftop Roots builds and maintains the gardens, then harvests the produce. However, the focus

isn't simply corporate and residential clients—the community also benefits.

"Our goal has been to grow food locally, create jobs for the unemployed, and create more green spaces," said Schneider. "Earlier this year, I took the plunge and left my government contracting job to focus full-time on Rooftop Roots, and ever since, our growth has been pretty crazy. We started our workforce development program, hiring individuals from the community who face barriers to employment, and began teaching them how to build and maintain edible and conservation landscapes. I'm excited that we are now beginning to hit our stride and are implementing the model as it was conceived. The future is bright!"

Rooftop Roots has been improving the economy, appearance, and environmental quality of the D.C. area in line with the university motto of *Ut Prosim* (That I May Serve).

"My time at Virginia Tech taught me that sustainable development is going to take integrative models that address not only the environmental aspect, but also the social and economic considerations. D.C. is unique in its 'Tale of Two Cities' structure," Schneider said. "There's a lot of money up here, but how can we drive that to lower-income areas? That is the dream now coming into fruition." ■

Brendan Coffey, a junior majoring in communication, is an intern with Virginia Tech Magazine.

CULTIVATING COMMUNITY: Thomas Schneider (middle) works with residents living the D.C. metro area to grow vegetables and economies.



COURTESY OF ROOFTOP ROOTS



TRAVELING HOKIES: (at left) The group visited Chateau Bernaville, Normandy, the site of the German headquarters during D-Day operations. (top) Mason Simpson rests outside the tour bus. (middle) The travelers stopped in Cleveux, Luxembourg. (above) Hokies enjoyed lunch at the Fletcher Hotel in the Netherlands.

BRAD SOUCY

LIVING HISTORY

MASON SIMPSON IS A HISTORY BUFF who doesn't like to travel—unless it's around the U.S. in his motorhome.

But what he described as a once-in-a-lifetime opportunity prompted him recently to join a dozen other Hokies in Europe to follow in the footsteps of Easy Company, reliving pivotal moments that changed the trajectory of World War II.

"This was so important to me. It was something I couldn't miss," said Simpson '69.

The trip, hosted by the Virginia Tech Alumni Association, followed the path of Easy Company's journey from Normandy to the Eagle's Nest, a Nazi outpost in Germany.

"You can't experience what the young men who fought the war went through," though the tour made the unimaginable a bit more real, Simpson said.

Simpson, 72, who was born a year after the war ended, describes himself as amateur historian with an interest in World War II geopolitics and considers Winston Churchill his favorite figure of the 20th century. He gained a new perspective from the trip as he visited a farmhouse that had been under Nazi occupation and stood beside American graves.

"It was hard for me," he said, "to be there and to understand how our guys were getting massacred and then to begin to understand the sacrifices they made to ultimately triumph."

Easy Company was part of the 506th Parachute Infantry Regiment, 101st Airborne. The group of men, many barely 20 years old, parachuted behind enemy lines on D-Day not knowing exactly where they would end up or what they would face. Their heroics were chronicled in the New

York Times bestseller "Band of Brothers," by Stephen E. Ambrose, which was later made into an HBO miniseries.

Jim Stewart '63 and his wife, Emy, also participated in the Normandy trip. After Emy Stewart survived cancer and brain surgery decades ago, the couple decided to take two to three large trips a year. They've traveled to Antarctica, Machu Picchu, Egypt, and most recently, Europe.

Stewart said he was often the first one out when the bus stopped at a site and the last to leave.

"I wanted to see everything and experience everything," he said.

The 78-year-old ran from the water at Omaha Beach up the shore. "To see the distance they had to come to storm the beaches into heavily fortified firepower was just amazing," Stewart said. "The opportunity to go see what these soldiers had gone through, just to physically witness the cliffs that the rangers had to climb in order to provide a way of attacking all the pillboxes and heavy artillery..."

Stewart found himself and others climbing in and out of foxholes in the Ardennes Forest trying to imagine what it was like for so many young men who fought Nazis and ultimately brought an end to World War II. "They sacrificed their lives so family and loved ones back home could live in freedom," he said. "There is life after this life. I just hope they are as proud of us as we are of them. They were the heroes of the Greatest Generation." ■

Annie McCallum is the director of communications for alumni relations.

LESSONS IN LEADERSHIP FROM EASY COMPANY



"ONE THING I WASN'T EXPECTING ON THIS TRIP WAS TO LEARN SO MUCH ABOUT LEADERSHIP. THE LESSONS FROM RICHARD DAVIS "DICK" WINTERS ARE PROFOUND.

HE HAD A BRILLIANT MILITARY MIND, BUT HE ALSO LOOKED AFTER HIS MEN— TRYING TO KEEP THEM SAFE, TOGETHER. HE WAS SELFLESS AND HUMAN.

HE PARACHUTED INTO NORMANDY ON D-DAY AND WOULD LATER BE THE COMMANDING OFFICER OF EASY COMPANY. WINTERS LED THE BRÉCOURT MANOR ASSAULT THAT DESTROYED A GERMAN BATTERY DESPITE THE FACT THE AMERICANS WERE OUTNUMBERED.

HE CARED FOR HIS MEN, AND THEY ALL SHARED A DEVOTION TO ONE ANOTHER. EASY COMPANY WAS ON THE FRONT LINES MUCH OF THE TIME. THEY HELPED EACH OTHER DAY BY DAY, MOMENT BY MOMENT. THAT BROTHERHOOD BETWEEN SOLDIERS, BUILT BY WINTERS, IS WHAT MADE EASY COMPANY SUCCESSFUL." ■

Brad Soucy, director of design and digital strategy in University Relations, served as a Virginia Tech host during the trip.



IN THEIR FOOTSTEPS: (above right) Memorial crosses at the Normandy American Cemetery and Memorial commemorate the loss of life during the war. (middle) Darryl "Shifty" Powers killed a German sniper in this location in Foy, Belgium. (bottom) The remnants of military foxholes are still evident in the woods at Bastogne, Belgium. (opposite) The Airborne Trooper Statue is a tribute to the American Airborne Soldiers of D-Day. The monument is located next to the bridge in La Fiere.

“

IT WAS HARD FOR ME TO BE THERE AND TO UNDERSTAND HOW OUR GUYS WERE GETTING MASSACRED AND THEN TO BEGIN TO UNDERSTAND THE SACRIFICES THEY MADE TO ULTIMATELY TRIUMPH."

Mason Simpson '69

BRAD SOUCY



A BRIGHTER WAY: LumenHAUS now resides on the Blacksburg campus adjacent to Cowgill Hall. (top right) Open house of LumenHAUS, 2011. (middle right) LumenHAUS 2010. (bottom right) On the Washington, D.C., Mall at the 2009 Solar Decathlon.

BACK TO THE FUTURE

VIRGINIA TECH'S CENTER FOR DESIGN Research has been exploring the architecture and engineering of energy-positive housing for more than two decades. The center designed and constructed its first solar house in 2002 to compete in the Department of Energy's inaugural Solar Decathlon competition in Washington, D.C.

The center's third prototype, LumenHAUS, debuted as its first "smart home." Although most energy-conscious houses sport a largely closed design to resist

heat transfer, LumenHAUS was created with an open pavilion concept, linking the house's occupants to each other and to nature outside. The north and south walls were all glass, maximizing exposure to bright, natural daylight. An automated system of sliding layers filtered light in throughout the day.

In 2010, LumenHAUS won the inaugural Solar Decathlon Europe competition in Madrid, Spain, and the structure was awarded the 2012 American Institute of Architects Honor Award for Architecture.

Over time, the center expanded its research to include smart home technologies and constructability.

In 2015, the center unveiled their kitchen of the future, followed by a bathroom and living room in 2016, and a bedroom and home office in 2017; together these living spaces form the FutureHAUS. In 2018, FutureHAUS Dubai won the Solar Decathlon Middle East in Dubai. (See related story on page 32.) ■ MA

JIM STROUP



ARE YOU IN?

DON'T MISS OUT ON VIRGINIA TECH GIVING DAY. MARCH 19-20 | BE SURE TO GIVE

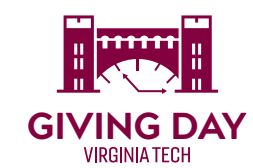

We're looking for 5,500 proud Hokies to step forward. Join us for 24 hours of impact and fun. Find opportunities to double the power of your giving. Learn more today. VT.EDU/GIVINGDAY | #VTGIVINGDAY



PARLAYING PICKLEBALL

HOW A PAMPLIN ALUMNUS PLANTED THE SEEDS OF HIS \$33 MILLION COMPANY AT VIRGINIA TECH

FOR A YOUNG ENTREPRENEUR WITH business on his mind, Virginia Tech was a great place to be in the '90s.

Coming out of high school in Virginia Beach, Ethan McAfee considered Virginia Tech to be ahead of the game in technology.

McAfee '98, a double-major in finance and accounting information systems, was head of SEED's technology sector, meaning that he chose what stocks to invest in the rapidly growing tech sector of the mid-90s. That put him in perfect position entering the job market at the height of the internet boom.

With an eye for spotting developing trends, McAfee turned his SEED experience into a job at investment firm T. Rowe Price, then became an early portfolio manager at the hedge fund Ramsey Asset Management, a career that introduced him to entrepreneurs from hundreds of companies, including Mark Cuban, Meg Whitman, and Jeff Bezos.

After 11 years, McAfee decided to make a change.

"I had all this knowledge about technology and internet companies," McAfee said. "I had always said that instead of investing in companies, it would be great to start my own."

In 2010, McAfee looked at the changing retail landscape in America and realized the potential for selling through Amazon, which he calls "the mall of the internet." Amazon's fulfillment services meant that an entrepreneur could build a retail business while keeping overhead costs low.

The next step was figuring out what to sell. Inspiration came from his parents, who lived in a Florida retirement community

that McAfee describes as "basically the pickleball capital of the world."

"Pickleball is this really fun game, like mini-tennis," McAfee said. "You play it with what looks like a big pingpong paddle, with a whiffle-ball on a tennis court. It's a co-ed sport, and it becomes very social. You get to talking, make friends, all these good things."

His parents complained, however, that they couldn't find pickleball equipment at local stores, only online. McAfee recognized the opportunity.

"Here's a rapidly growing niche product you can't find at local stores," McAfee

said. And there weren't that many products to sell, which allowed him to invest in a smaller inventory and still compete with bigger retailers.

McAfee launched his company in 2010 and rapidly expanded to incorporate other products. Today, the company that started out as Pickleball Direct and became Amify in 2017 employs around 50, has sold more than \$100 million of products through Amazon, and has made the Inc. 500 list twice and the Inc. 5,000 list four times. Amify is headquartered in Alexandria, Virginia, with a satellite office in Las Vegas. ■ MA

COURTESY OF JEREMY BRANDT-VOREL

COURTESY OF PAIGE KASSALEN



Employees at Amify, which was founded by Ethan McAfee (back row, fourth from left) in 2010.



FULL SPEED AHEAD

FROM PLANES TO CARS, THERE'S NO stopping 25-year-old alumna Paige Kassalen.

One year after graduating from Virginia Tech, Kassalen '15 was the youngest member of the ground crew responsible for the takeoff and landing of the Solar Impulse, the first solar-powered plane to make a trip around the world. She was also the only American and one of two women involved.

It's no surprise, then, that around 12 months after her journey with Solar Impulse, Kassalen made the Forbes Magazine "30 Under 30" list, which annually profiles 600 of what the magazine calls the "brightest young entrepreneurs, innovators, and game-changers."

"That was a moment where your heart drops, and you're just so confused about how you achieved this career goal that you didn't know would actually be possible," said Kassalen.

Kassalen hopes to soon pursue an MBA, start her own company, and give back to Virginia Tech however she can.

Kassalen was recently elected to be on Virginia Tech's Bradley Department of Electrical and Computer Engineering Industrial Advisory Board. She is no

stranger to juggling multiple leadership roles while simultaneously giving back to her community through volunteer work.

"I really feel like I am who I am today because of my experience at Virginia Tech, and I want to thank them for that," she said. ■

Stephanie Kapllani is a communications specialist in the Virginia Tech College of Engineering.



THAT WAS A MOMENT WHERE YOUR HEART DROPS, AND YOU'RE JUST SO CONFUSED ABOUT HOW YOU ACHIEVED THIS CAREER GOAL THAT YOU DIDN'T KNOW WOULD ACTUALLY BE POSSIBLE."

Paige Kassalen '15

WOMAN TO WOMAN

NETWORK NEWS: Four alumnae spoke during a Women in STEM event in September 2018 at the Virginia Tech Carilion School of Medicine. The alumni panelists were, from left to right, Ashley Flora '07, Jennie Zabinsky '09, '13, Teresa Martinez '92, '98, and Mary Guy Miller '72, '85, '96.



ENGAGING THE HOKIE ALUMNAE NETWORK

MARY MILLER '85 NEVER THOUGHT about gender differences growing up. The rules at home applied equally to her and her male and female siblings.

This is why Miller, a College of Engineering alumna and director of the Regional Accelerator and Mentoring Program, often is surprised that some people do not expect to find women working in traditionally male-dominated fields.

“We cannot afford to not be inclusive,” said Miller, one of four panelists who spoke at an alumni event, Women in STEM (science, technology, engineering, and mathematics), last September at the Virginia Tech Carilion School of Medicine.

In the past year, the Virginia Tech College of Science, in partnership with the

Alumni Relations office, has organized a series of Women in STEM networking events in Virginia and North Carolina. They are meant to encourage women to consider careers in science, technology, engineering, and math and to support females who already work in these fields.

The events fall under a large umbrella of industry networking opportunities offered by Alumni Relations in partnership with colleges across the university. The events are held across the country and connect alums of different career stages and backgrounds.

For nearly 10 years, the Pamplin College of Business has hosted Women in Business events for professionals at all stages to network and discuss issues that women face in navigating business

careers. These events draw alumni as well as current and prospective students, and they feature keynote speakers or alumni panelists who represent various Virginia Tech colleges.

More networking events are planned this year, with Women in STEM gatherings set for February in Richmond and Northern Virginia. Women in Business events will include gatherings in March in Northern Virginia; April in Charlotte, North Carolina; and September in New York.

“The biggest thing is the encouragement through incredible alumnae who speak about supporting each other,” said Katie Lafon, director of alumni relations for the College of Science. ■ JB

STEVE MACKAY



MILESTONE MOMENTS

DURING MY LIFETIME, I HAVE witnessed what I believe to be some of Virginia Tech’s most historic moments—the presentation of an honorary degree to Irving Linwood Peddrew III, the first African American student to attend our university; the generosity of the Fralin family in making the largest gift our university has ever received; and the etching of additional names on the Pylons honoring Hokie alumni lost in service to our nation. There was also the opening of the Moss Arts Center, the creation of the medical school, and watching the end of the 2012 Sugar Bowl versus Michigan—and yes, Danny Coale caught that ball!

As I reflect on those events and many others, I consider the Innovation Campus announcement in November 2018 among our milestone moments.

In the days and weeks that have followed, the excitement expressed by our alumni

has been amazing. What I have heard from countless Hokies across the nation and around the world echoes what I feel myself: pride in my alma mater, in the Virginia Tech leadership team, and in our alumni family.

We have always known what we are capable of—and now others around the world are getting a glimpse of that as well.

Through the Innovation Campus, Virginia Tech will expand its footprint in the greater Washington, D.C., area to deliver on a promise to develop the leaders and innovators of the future. The plans for our new campus, which will be positioned just two miles from Amazon’s new headquarters in Arlington, contributed significantly to the success of Virginia’s bid to attract the online retailer. Hokies are not new to Amazon; more than 300 Virginia Tech alumni work at the company already.

Many of you have shared that the

Innovation Campus announcement was an affirmation of Virginia Tech’s prowess and cements its national reputation as a technology powerhouse. The more than 60,000 Hokies who live in Northern Virginia are thrilled to see their university represented in the region in a new way.

It is gratifying to watch as our presence expands and we build something new from the ground up. The Innovation Campus will bring together a new community of Hokies and will serve as a valuable addition to our other sites in the geographic area.

But, beyond the academic and leadership opportunities, the tremendous enthusiasm from you, our alumni, and your continuing interest in being a part of our future fuels my pride and renews my energy around what is next for this great university.

Now—LET’S GO! ■

Matthew M. Winston Jr. '90 is senior associate vice president for alumni relations.

DM

FAMILY

1 “Molly, VT Class of 2040, is already sporting maroon and orange and cheering on her Hokies.” —Melissa Trotman Hollinshead '08, Chesterfield, Va., who along with Mark Hollinshead '09, welcomed a daughter, Molly Jean, 7/3/18.



MELISSA HOLLINSHEAD '08

2 “In August, Hokie-in-training Winnie Wittelsberger took her first trip to the beach at Fenwick Island, Del.” —Stacey Rector Wittelsberger '08, Baltimore, Md., who, along with Ray Wittelsberger '08, welcomed a daughter, Windsor, 8/1/18.



STACEY WITTELSBERGER '08

3 “We had a Hokie wedding officiated by James Friend Dickerson '84 in Albemarle County, Virginia.” —Shannon Farley Harrison '93, who married Robert Alexander Harrison III '80.



KELSEY H. KIRSGANICK '13

4 “The Showalter family, Jaime, Eloise, and Andrew '09, dressed to watch the Hokies defeat Marshall on Dec. 1, continuing Virginia Tech's bowl streak.” —Andrew Showalter '09, Fairfax, Va., who welcomed a daughter, Eloise Adele, 11/12/18.



JAI ME SHOWALTER

5 “Fashion forward in her favorite colors, maroon and orange,” —Sharnnia Artis Trimble '02, M.S. '05, Ph.D. '07, Irvine, Calif., who welcomed a daughter, Skylar Amari, 2/7/18.



SHARNNIA ARTIS TRIMBLE '02



JENNY MISTALSKI PHOTOGRAPHY



STEPHANIE BEHLING '01

6 “Sweet dreams of bowl games and March Madness.” —Erin Coe Fristoe '01, Woodbridge, Va., who, along with John K. Fristoe '01, welcomed a daughter, Keegan Colleen, 2/27/18.

7 “Brennan's initials are BMW, so we've nicknamed him Beamer. He is always charming people with a big grin and a squeal.” —Stephanie Behling '01, Frederick, Md., who welcomed a son, Brennan White, 6/12/18.



BONNIE HAMILTON '08

8 “Henry Hollar is enjoying his first visit to Virginia Tech.” —Bonnie Hamilton '08, Richmond, Va., who, along with Quentin Penn-Hollar '08, welcomed a son, Henry, 3/26/18.

9 “Beckett Grady arrived in April, just six days before his brother, Easton Carter, turned two.” —Mandi Hogan Green '09, Hanover, Va., who, along with Ryan Green '08, welcomed a son, Beckett Grady, 4/20/18.



LINDSEY MARTIN PHOTOGRAPHY

IN MEMORIAM

Listing includes notices shared with the university April 2 through Sept. 30, 2018.

'38

Edith Price Sloop, Blacksburg, Va., 4/9/18.

'42

Ernest L. Hurd Jr., Silver Spring, Md., 1/14/18.

Paul M. Fletcher, The Villages, Fla., 5/29/18.

'43

Benjamin W. Wyche III, Arlington, Va., 2/24/18.

'44

Burton L. Kelchner, Lakewood, Colo., 5/31/18.

William C. Lucas Jr., Du Bois, Pa., 3/9/18.

Robert George Smola, Newport News, Va., 4/16/18.

Arthur W. Ordel Jr., Keswick, Va., 9/17/18.

'45

John Robert Kautz, Nitro, W. Va., 4/3/18.

'46

Kearney F. McQuilkin, Annapolis, Md., 5/15/18.

William P. Maddy, Springfield, Mo., 4/4/18.

'47

Albert Pierce Super, Norfolk, Va., 3/14/18.

William Buchanan Coffman, Silver Spring, Md., 5/30/18.

Bernard "Ben" C. Meredith Jr., Panama City, Fla., 4/30/18.

Elva L. Reynolds Burghardt, Colorado Springs, Colo., 4/30/18.

Evelyn Patton Daniel, Glen Allen, Va., 5/16/18.

'48

Robert H. Walton Jr., Christiansburg, Va., 4/26/18.

Robert Taylor Lawson, Hampton, Va., 4/11/18.

'49

Harry Randolph Jordan, Gloucester Point, Va., 6/18/18.

Earl Raymond Simpson Jr., Lynchburg, Va., 4/22/18.

Charles Franklin Trent, Roanoke, Va., 5/15/18.

Robert Smith Kern, Winchester, Va., 3/4/18.

Robert Chester Jennings, Wytheville, Va., 5/21/18.

Truman L. Sayre, Ghent, W. Va., 5/6/18.

'50

W. Lewis Motley, Ringgold, Va., 3/31/18.

William Allen Thrasher, Smithfield, Va., 3/14/18.

Blaine Frank Parker, Lexington, Ky., 6/17/18.

Connie Larue Sellers, Roanoke, Va., 3/29/18.

Edwin G. Gatling, Newport News, Va., 3/30/18.

Walter Harris Pogue Jr., Lancaster, Pa., 5/9/18.

William Whiting McClanahan, Little River, S.C., 4/26/18.

James Don Isley, Kingsport, Tenn., 5/17/18.

'51

Robert E. Mauzy Jr., Blue Grass, Va., 5/14/18.

Carl J. Arnold, Clinton, S.C., 5/15/18.

Robert L. Moore, Haymarket, Va., 4/28/18.

William "Ray" Kluge, Virginia Beach, Va., 6/12/18.

S. Clyde Watkins, Lakeland, Fla., 6/2/18.

Lawrence J. Klebert, North Chesterfield, Va., 5/22/18.

Vernon C. Walton, Richmond, Va., 9/12/18.

Roger M. Bottoms, Sterling Heights, Mich., 8/1/16.

David Arthur Olsen, North Myrtle Beach, S.C., 5/4/18.

'52

Robert James Tinder, Pittsburgh, Pa., 4/25/18.

Riley Emory Brubaker, Rocky Mount, Va., 4/1/18.

Donald F. Simpson Sr., Alexandria, Va., 5/14/18.

Jack David Owen, Venice, Fla., 4/13/18.

'53

Thomas W. Barham, Fairfax, Va., 5/13/18.

Jack H. Abbott, Sumter, S.C., 4/16/18.

George Warren Swift, Blacksburg, Va., 5/28/18.

William B. Allen Jr., Atlanta, Ga., 6/8/18.

Ronald Baber Whitehead, Pembroke, Va., 6/18/18.

William D. Pollard, Petersburg, Va., 5/12/18.

Melvin D. Wagstaff, El Paso, Texas, 3/31/18.

Glenn S. Fowler, Bethlehem, Pa., 4/24/18.

'54

John Linton Hainer, El Paso, Texas, 6/5/18.

Donald R. Trippeer, Greenville, N.C., 3/5/18.

Thomas Gardner Hines Sr., Suffolk, Va., 6/5/18.

Edwin Surber Bolen Jr., Lynchburg, Va., 4/23/18.

'55

Altamont Dickerson Jr., Ashland, Va., 4/2/18.

Robert William Eagan Jr., Manakin-Sabot, Va., 8/7/18.

James Price Newbill, Shiloh, Ga., 9/16/18.

John Bryan Hall Jr., Yorktown, Va., 3/17/18.

John Willis Muncy, Bland, Va., 5/27/18.

John F. Kane Jr., Franklin, Mich., 9/18/18.

'56

Donald L. Sage, Henrico, Va., 4/4/18.

Aubrey McCoy Foster Sr., Smyrna, Ga., 3/20/18.

Alan Page Stadler Sr., Little River, S.C., 4/30/18.

Winfield Massie, Spring, Texas, 5/14/18.

Richard G. Cornell, Saline, Mich., 4/2/18.

Philip C. Holladay Jr., Richmond, Va., 6/13/18.

'57

Maurice N. "Buddy" Early, Norfolk, Va., 9/15/18.

Roy M. Miller, Fairfax, Va., 3/11/18.

Robert E. Speas, Rockingham, Va., 3/25/18.

David A. Hilton, Chesapeake, Va., 5/3/18.

James S. Fowler, Memphis, Tenn., 5/15/18.

Thomas M. Hall, Charles City, Va., 6/20/18.

'58

Daniel W. Pruitt, Blackstone, Va., 5/31/18.

John E. Hinckle, Richmond, Va., 2/16/18.

Parks Adolphas Deaton, Worthington, Ohio, 4/27/18.

Thomas P. Johnson Jr., Suffolk, Va., 6/22/18.

William Glen Wilson Sr., New Bern, N.C., 3/10/18.

'59

Buddy W. King, Mechanicsville, Va., 5/24/18.

Raymond Stanley Kirchmier II, Henrico, Va., 5/18/17.

Claude Charles Barnett, Taylors, S.C., 5/25/18.

Ping-Fan Chen, Morgantown, W. Va., 5/19/18.

Richard C. Chin, New York, N.Y., 11/7/17.

Kenneth H. Sellers, Burke, Va., 4/20/18.

Robert A. Wilmarth, Durham, N.C., 4/18/18.

Richard A. Lechner, Toms River, N.J., 5/12/18.

'60

Adrian T. Creech, Wilmington, N.C., 4/5/18.

William Michael Brackney, Baton Rouge, La., 6/10/18.

Oscro James Kennedy, Virginia Beach, Va., 5/22/18.

Beulah Stowers Fox, Bishopville, S.C., 6/23/18.

'61

William Frank Cooper, Cumming, Ga., 3/10/18.

Alexander Thomas Ovenshine, Palo Alto, Calif., 6/2/18.

Fred L. Jennings, Fries, Va., 4/10/18.

Malcolm Lee Cook, Athens, Ala., 3/4/18.

James Goodson III, Danville, Va., 3/30/18.

Anthony J. Catalano, Triangle, Va., 5/14/18.

Dennis Edward Hardy, North Tazewell, Va., 4/23/18.

John Temple Fray, Madison, Va., 3/28/18.

'62

Frederick Emerson Hughes Jr., Richmond, Va., 5/29/18.

Elwood Gordon Ball Jr., Heathsville, Va., 5/27/18.

Thomas Guilford Sixbey, Salem, Va., 6/6/18.

Sammie Garland Hughes, Baytown, Texas, 3/10/18.

Samuel Cameron Reid, Hiwassee, Va., 6/10/18.

Irving Wayne Swann, Mechanicsville, Va., 4/25/18.

'63

James Richmond Fisher, Norfolk, Va., 2/18/18.

Bruce Wade Asai, Malibu, Calif., 3/19/18.

'64

Eugene Paul Tinus, West Chester, Pa., 6/6/18.

Charles Ashley Wrenn, Franklin, Va., 6/8/18.

William Oscar Lipscomb III, Chiefland, Fla., 6/19/18.

James Alexander Mundy IV, Springfield, Mass., 5/3/18.

Otto Alexander Sanders, Newbury Park, Calif., 6/4/18.

William Hevener, Roper, N.C., 3/31/18.

'65

Richard Edward Bass Jr., Blacksburg, Va., 2/10/18.

James Gray Neale Jr., Farmville, Va., 5/30/18.

Edward Nils Resio, Fredericksburg, Va., 4/20/18.

Donald William Mayberry, Salem, Va., 4/25/18.

'66

John Alton Elder Jr., Versailles, Ky., 9/17/18.

'67

John Thomas Benton, Midlothian, Va., 4/2/18.

Timothy Barry Wilson Sr., 9/11/18.

Garnett Graham Gamble, Centreville, Va., 3/15/18.

'68

Walter Leroy Ashley, Lynchburg, Va., 3/16/18.

Michael Joseph Bogese Jr., Richmond, Va., 4/24/18.

'69

John Wingo Long, Mechanicsville, Va., 3/30/18.

Edward Joseph Jenkins, Springfield, Va., 3/1/18.

Garrett W. Hall, Monkton, Md., 5/25/18.

Richard Allen Curtis, Richmond, Va., 5/31/18.

Stephen W. Pavlik, Gainesville, Fla., 4/11/18.

Kenneth Stuart Culnan, Strasburg, Va., 4/26/18.

'70

Russell Lewis Arbaugh, Waynesboro, Va., 5/28/18.

Jackie Conrad Lankford, Summerfield, N.C., 4/24/18.

John Brown Bell Jr., Columbia, Md., 5/10/18.

Cary Rayford Williams, Newport News, Va., 5/31/18.

Thomas H. Shelton, Roanoke, Va., 5/2/18.

'71

Suzanne Clare Goedel, King George, Va., 3/2/18.

Bruce W. Fussell, Port Royal, Va., 5/4/18.

Lane Bradley Canada, Roanoke, Va., 3/8/18.

'72

Sidney Charles Englander, Metairie, La., 6/21/18.

Michael Joseph Santangelo, Iowa City, Iowa, 4/25/18.

John Buchanan Carland, Blacksburg, Va., 5/14/18.

Joseph Stephen Newton, Locust Grove, Va., 4/26/18.

Bobby Ray Goodman, Roanoke, Va., 4/15/18.

'73

William Loch Bow, Hollidaysburg, Pa., 5/22/18.

Danny Lee Glenn, Jonesborough, Tenn., 4/28/18.

Calvin Weldon Easter, Richmond, Va., 4/28/18.

'74

Sidney Braxton Moody, Henderson, N.C., 6/3/18.

Stephen Michael Reynolds, Lynchburg, Va., 5/26/18.

Dianne Morie Portner, King George, Va., 3/28/18.

Michael Lynn Benson, Elizabethtown, Pa., 4/2/18.

Walter Marvin Duncan Jr., Dallas, Texas, 3/24/18.

Patricia Lou Walochik, Lilburn, Ga., 6/4/18.

'75

Gregory James Romanowski, Cape Coral, Fla., 6/12/18.

Jerry Lee Chambers, Princeton, W. Va., 4/30/18.

Billy Hamner Patterson, Bedford, Va., 9/18/18.

Kelvin Howard Wildman, Honey Falls, N.Y., 4/18/18.

Roger T. Stevens, Rio Rancho, N.M., 5/30/18.

'76

Charles Arthur Ware Jr., South Boston, Va., 5/3/18.

Roberta S. Messamer, Bridgewater, Va., 5/8/18.

'77

Richard Patrick Steele, Midlothian, Va., 6/4/18.

Jesse Harold Perdue Jr., Roanoke, Va., 3/18/18.

Mary Jo Shilling Shannon, Roanoke, Va., 4/2/18.

Richard Eugene Lenker, Premora, Va., 4/17/18.

'78

James Mapp Chandler, Norfolk, Va., 5/4/18.

Joseph Douglas Stogner, Callaway, Va., 4/6/18.

Bruce Conrad Schepens, Las Vegas, Nev., 3/3/18.

'79

Mark Edward Vermillion Sr., Londonderry, N.H., 5/4/18.

Margaret Jones Davidson Irvin, Roanoke, Va., 6/17/18.

Arthur Lazarow, Hickory, N.C., 6/10/18.

'80

Arthur Laverne Wilson, Lexington, Va., 5/10/18.

William Bainbridge Hayden, Fairfax, Va., 4/12/18.

'82

Jill Gift Lockhart, Matthews, N.C., 4/16/18.

John George Heffner, Davidson, N.C., 2/5/18.

Joseph Paul Fontenot Jr., Bel Air, Md., 4/17/18.

'83

Michael Edward Brigham, Colleyville, Texas, 5/2/18.

Roger Barry Shields, Marion, Va., 4/21/18.

Royal Earl Jones III, Richmond, Va., 6/6/18.

'84

Dorothy L. Martz Watts, Oakton, Va., 3/31/18.

Kathleen Marie Coleman, Blacksburg, Va., 4/14/18.

Susan Jackson Reid, Tampa, Fla., 9/13/18.

'85

Robyn Costigan Rowland, Marion, Va., 5/24/18.

William W. Hurt, Naruna, Va., 5/1/18.

'86

Roman Wolodymyr Dychdala, Phoenixville, Pa., 4/25/18.

Jeffrey David Morris, Smithfield, Va., 3/13/18.

'87

Amy K. Blackburn Owens, Quinton, Va., 4/13/18.

'88

Lisa Ann Black Starling, Virginia Beach, Va., 5/30/18.

'89

Megan "Margaret" Helen Dorsett, Christiansburg, Va., 1/30/18.

Charles Lenwood Garnett, Boydton, Va., 6/6/18.

'93

Dorris Phay Cooper Taylor, Alexandria, Va., 5/7/18.

Myron Howard Sipe, Elkton, Va., 5/31/18.

'94

Ryan Thomas Campbell, Martinsburg, W.Va., 5/21/18.

'95

Alice Mathena LoMascolo, Christiansburg, Va., 4/1/18.

Timothy J. Conway, Haymarket, Va., 5/28/18.

Roger Allen Asbury, Pulaski, Va., 5/15/18.

'96

Mark D. Piechoski, Blacksburg, Va., 3/30/18.

Michael Rand Bunker, Mechanicsburg, Pa., 6/17/18.

'02

William Henderson Johnson Jr., Farmville, Va., 5/10/18.

'03

Spencer L. Joslin, Blacksburg, Va., 4/16/18.

'04

Kelly D. Holzhauser, Stephens City, Va., 5/1/18.

'06

Adam Thomas Waldrop, Roanoke, Va., 6/14/18.

'11

Jeanne Esther Goodwin, Virginia Beach, Va., 6/14/18.

'15

April Leigh Saul, Catawba, Va., 3/26/18.

OBITUARIES

David Allen Fiske, superintendent of the Virginia Tech Shenandoah Valley Agricultural Research and Extension Center in Raphine, Virginia, died Nov. 16, 2018.

Professor Emeritus John F. Hosner, honorary founding dean of the College of Natural Resources and Environment, died Sept. 13, 2018. Hosner joined the Virginia Tech in 1961 as head of the newly established Department of Forestry and Wildlife, which was then part of the College of Agriculture.

Susan West Marmagas, director of Virginia Tech's Master of Public Health program and associate professor of practice in the Department of Population Health Sciences, died Dec. 23, 2018. Marmagas joined Virginia Tech in 2008 and establish the university's public health program and Center for Public Health Practice and Research.

Dilip Kumar Shome, professor emeritus of finance, died Dec. 7, 2018. A member of the Virginia Tech community since 1983, he was head of the Department of Finance, Insurance, and Business Law in the Pamplin College of Business from 1996 to 2000. He retired in 2014.

VIRGINIA TECH magazine



Visit us online to read even more stories about your fellow Hokies, find links to events and campus activities, and stay up-to-date on university news.

VTMAG.VT.EDU

STAY CONNECTED

MAKE SURE THE UNIVERSITY HAS YOUR UP-TO-DATE MAILING AND CONTACT INFORMATION. USE YOUR VIRGINIA TECH PID AND PASSWORD TO VIEW AND MAKE CORRECTIONS TO YOUR MAILING ADDRESS, EMAIL ADDRESS, AND OTHER INFORMATION. YOU CAN INSPECT AND UPDATE YOUR ALUMNI PROFILE ANYTIME, FROM ANYWHERE.

IT'S EASY TO UPDATE YOUR CONTACT INFORMATION AND EMAIL ADDRESS AT ALUMNI.VT.EDU.

- CLICK "UPDATE YOUR CONTACT INFORMATION"
- LOGIN WITH YOUR VT PID AND PASSWORD
- CHOOSE "HOKIE PLUS"
- THEN CHOOSE "UPDATE ADDRESS(ES) AND PHONE(S)" OR "UPDATE ALUMNI EMAIL ADDRESS(ES)"

YOU CAN ALSO EMAIL YOUR UPDATES TO ALUMNIDATA@VT.EDU. MAKE SURE YOU INCLUDE YOUR FULL NAME AND CLASS YEAR IN THE EMAIL.



STILL
LIFE

JUMP-START: Students gathered at the Duck Pond Amphitheater on Oct. 29, 2018, for the Homecoming Campfire Kickoff. Participants roasted marshmallows, met the candidates for Homecoming Court, and enjoyed a capella music. The event was hosted by the Virginia Tech Homecoming Board, a select group of undergraduate students who help plan and oversee many of the Homecoming Week activities.



Theresa Mayer

END NOTE

RESEARCH AND INNOVATION: LOOKING BACK AND MOVING FORWARD

LAST YEAR MARKED THE 30-YEAR anniversary of my graduation from Virginia Tech. January 2018 marked my third year back on campus, this time as Virginia Tech's vice president for research and innovation and professor of electrical and computer engineering.

As I look back, I am struck by Virginia Tech's transformational growth. When I visited campus with my husband and twin sons in 2016, I had trouble finding my freshman residence hall among the state-of-the-art research and instructional buildings that had been constructed in the interim. I am sure many of you have had similar experiences during your return visits to Blacksburg.

Amid these dramatic changes, I have been pleased that Virginia Tech has remained true to its rich history and core values as a land-grant university, which are best expressed by our motto, *Ut Prosim*, (That I May Serve). As a first-generation college student from Hampton Roads, Virginia Tech gave me the opportunity to learn from faculty who were world-renowned leaders in education and research.

My mentors and colleagues at Virginia Tech and at my next two land-grants—Purdue and Penn State—also taught me the value of collaborating across boundaries, striving to make a difference and to be excellent, making the most out of every opportunity (expected and unexpected), and persevering in the face of challenges. These essential aspects of the land-grant spirit and culture characterize our exceptional faculty, staff, and students.

Public impact research, which has always been central to our mission, also attracts many of the best and brightest faculty and students from around the globe to Virginia Tech. Our long history of research leadership is evident.

In 1989, we were among the first institutions in the nation to win funding for a National Science Foundation (NSF) Science and Technology Center (STC) in high-performance adhesives and composite materials. That center has been credited with breakthrough discoveries across a wide-range of fields from optical devices to fuel cells.

Three years ago, we were named home to a multi-university Molecular Sciences Software Institute, one of only two major NSF-supported hubs for scientific software innovation to serve the worldwide community.

Ten years after the NSF STC, we were awarded a prestigious NSF Engineering Research Center (ERC) on Power Electronic Systems. This program pioneered a model for industry affiliation and technology commercialization that has been adopted by universities across the nation. Now, the center faculty and students collaborate with more than 80 industry partners to radically transform electronic systems-level technologies used to power everything from microprocessors to electric vehicles to cities.

In 2018 we celebrated the 40th anniversary for our Center for Gerontology. This hallmark center fosters multidisciplinary research to enhance quality of life for older adults, addressing a nationwide challenge. Last year marked 30 years of transportation innovation at the Virginia Tech Transportation Institute, which houses

the second largest group of transportation safety researchers in the country.

Our university has recorded substantial growth over the past three decades. In 1988, Virginia Tech had nearly 1,500 instructional and research faculty, 18,400 undergraduate students, 2,900 graduate students, and \$89 million in annual research expenditures. Since then, we have grown undergraduate enrollment by 50 percent, doubled our graduate students, and increased annual research expenditures to \$523 million. Impressively, more than half of our undergraduates participate in experiential learning and research each year. In 1998, we published 1,500 scholarly articles, compared to more than 4,700 today.

Yet through all of these changes, we have remained true to our commitment as a comprehensive land-grant university.

Today, Virginia Tech is involved with leading research across engineering, business, arts, design, agriculture, life and environmental sciences, veterinary medicine, biomedical, and health sciences. And that research is supported by nearly every federal agency. Our industry partnerships are among the strongest in the nation. Our research institutes bridge disciplinary and organizational boundaries to support studies that matter.

Very few universities have made the investments or formed the partnerships that Virginia Tech has, and the results speak for themselves. Our junior faculty received 15 prestigious NSF Faculty Early CAREER awards in 2018, bringing our total to 39 active faculty. We are home to award-winning creative works, performing arts, and humanities research. In fact, from April 5-7 at the National Museum of American History, the ACCelerate Festival will feature some of these creative installations and performances. If you are in the area, I hope you will join us for this special event.

This year looks like another exciting year

for Virginia Tech's research enterprise, complete with opportunities to impact the economic development and prosperity of the commonwealth. The newly endowed Fralin Biomedical Research Institute at VTC and the addition of the Virginia Tech Carilion School of Medicine as our ninth college will continue to drive interdisciplinary work in health sciences and will benefit Roanoke and the New River Valley. Likewise, our leadership of the Commonwealth Cyber Initiative will fuel an engine of growth focused on cybersecurity technologies across Virginia. But there is more work to be done.

When Amazon announced plans to add a second headquarters, company leaders sought a region with a highly skilled and tech-savvy workforce and an existing ecosystem proven to produce top-notch graduate talent and cutting-edge research. Virginia Tech provided that assurance.

In November 2018, we announced a \$1 billion Innovation Campus in Alexandria, which was catalyzed by Virginia's investment in higher-education. Moving forward, we will continue to develop our campuses in Northern Virginia as a global gateway.

Building on a proven track record of molding future leaders, thinkers, and innovators, Virginia Tech is looking to the future, enhancing comprehensive programs, developing strategic partners across the commonwealth and beyond, and advancing the mission of the land-grant university.

By growing research across the boundaries of disciplines and institutions, we are working with our partners to solve and deliver solutions for the grand challenges of the 21st century.

The future of research and innovation at Virginia Tech is brighter than ever! ■

Theresa Mayer is the vice president for research and innovation at Virginia Tech.



CASE STUDY: Theresa Mayer, vice president for research and innovation, converses with Jack Finney, vice provost for faculty affairs, prior to a meeting in spring 2018.

IN OUR NEXT ISSUE

Virginia Tech continues to unveil bold initiatives that link traditional academic strengths with creative new ideas. Understanding that innovation begins with imagination, in 2016, the university announced plans to form a Creativity and Innovation District along the eastern edge of campus where it intersects with downtown Blacksburg, designating spaces to nurture ideas and encourage entrepreneurship.

In our summer issue, learn more about how this initiative is moving education and research forward. Also, read a story about a class where students can visit WWI bunkers virtually and find out about research projects that blur the lines between art and science.

Look for these stories and more in your next issue.

UNIVERSITY RELATIONS
902 PRICES FORK ROAD
UNIVERSITY GATEWAY CENTER, SUITE 2100
BLACKSBURG VA 24061

PRSR STD
U.S. POSTAGE
PAID
LYNCHBURG, VA
PERMIT NO. 542

CHANGE SERVICE REQUESTED



CLAIM YOUR ROLE



Virginia Tech is home for the curious, the bold, the insatiable.
A thirst for knowledge propels us, a call for service unites us.
Research. Discovery. Impact.

That's our role. Discover yours... vt.edu